

<b>6.0</b>	<b>RIDUTTORI A VITE SENZA FINE CON DOPPIA USCITA</b>	<b>DOUBLE OUTPUT WORM GEARBOXES</b>	<b>SCHNECKENGETRIEBE MIT ZWEI AUSGANGSWELLEN</b>	
6.1	Caratteristiche	<i>Characteristics</i>	Merkmale	112
6.2	Designazione	<i>Designation</i>	Bezeichnung	112
6.3	Dati tecnici	<i>Technical data</i>	Technische Daten	113
6.4	Lubrificazione	<i>Lubrication</i>	Schmierung	114
6.5	Carichi radiali e assiali	<i>Radial and axial loads</i>	Radial und axial Belastungen	114
6.6	Dimensioni	<i>Dimensions</i>	Abmessungen	115

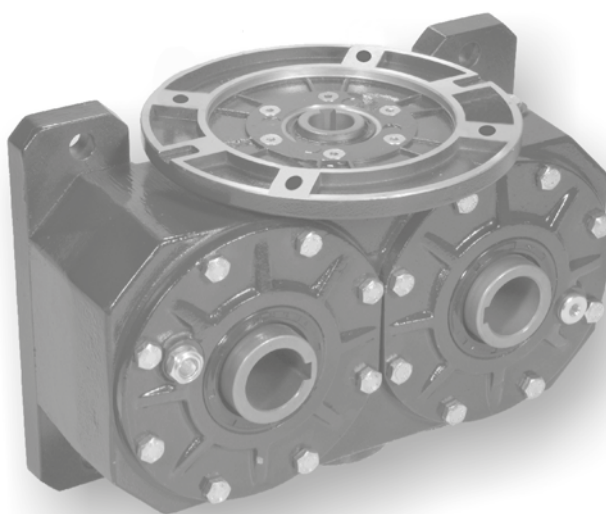

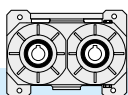

La serie di vite senza fine con doppia uscita comprende riduttori costruiti appositamente per soddisfare delle specifiche esigenze di automazione.

Il cinematismo, composto da una vite senza fine e due corone, consente di disporre, all'uscita, di due alberi cavi con una rotazione sincrona controrotante.

La motorizzazione può essere effettuata tramite motori elettrici o motovariatori provvisti di una flangia di fissaggio dimensionata a norme IEC.

*Double output worm gearboxes series includes gearboxes specially manufactured to comply with specific requirements.*

*The kinematic motion is carried out by means of a wormshaft and two wormwheels in order to have two output shafts with a synchronous rotation.*

*These gearboxes can be assembled to electric motors or moto variators fully comply with the IEC specifications.*

Bei der Schneckengetriebe mit Zwei Ausgangswellen Serie handelt es sich um Schneckengetriebe, die für spezielle Antriebsaufgaben eingesetzt werden.

Der Aufbau besteht aus einer Schnecke und zwei Schneckenräder umgewandelt. Der Antrieb erfolgt durch IEC Normmotoren oder Verstellgetriebemotoren.

### 6.1 Caratteristiche

- **Corpo e flange**  
Costruiti in alluminio e verniciati colore BLU RAL 5010
- **Vite senza fine**  
In acciaio legato. Indurita tramite cementazione e tempra e finita di rettifica
- **Corona**  
Fascia dentata in bronzo GcuSn12 UNI 7013 riportata di fusione su mozzo in ghisa G20 UNI 5007
- **Cuscinetti**  
Sulla vite e sulle due uscite sono montati cuscinetti a rulli conici
- **Lubrificazione**  
Normalmente i riduttori vengono forniti privi di lubrificante. Su richiesta possono essere forniti con lubrificante sintetico

### 6.1 Characteristics

- **Casing and flanges**  
*Made from aluminium and painted BLUE RAL 5010*
- **Worm screw**  
*Made from alloy steel. Hardened and case-hardened then finished by grinding*
- **Worm wheel**  
*UNI 7013 GcuSn12 bronze toothed band. Inserted by casting on UNI 5007 G20 cast-iron hub.*
- **Bearings**  
*Taper roller bearings are mounted on the screw and on the two outputs*
- **Lubrication**  
*Gearboxes are normally supplied without lubricant. However, they can be supplied with synthetic lubricant on request*

### 6.1 Merkmale

- **Gehäuse und Flansche**  
Aus Aluminium gefertigt und mit Farbe BLAU RAL 5010 lackiert
- **Schnecke**  
Aus legiertem Stahl. Gehärtet durch Einsatzhärtung und Abschreckhärtung mit Fertigschliff
- **Zahnkranz**  
Zahnband aus Bronze GcuSn 12 UNI 7013, aufgegossen auf Nabe aus Guss-eisen G20 UNI 5007
- **Lager**  
Auf der Schnecke und auf den beiden Abtrieben werden Kegelrollenlager montiert.
- **Schmierung**  
Normalerweise werden die Getriebe ohne Schmiermittel geliefert. Auf Anfrage können sie mit synthetischem Schmiermittel geliefert werden

### 6.2 Designazione

### 6.2 Designation

### 6.2 Bezeichnung

Riduttore Gearbox Getriebe	Tipo entrata Input type Antriebsart	Grandezza Size Größe	Rapporto rid. Ratio Untersetzung	Predispos.att. mot. Motor coupling Motoranschluss
<b>VSF.2USC.</b>	<b>VM</b>	<b>135</b>	<b>40</b>	<b>pam 200/19</b>
	<b>VM VI</b>	<b>135 150 170 230</b>	<b>i</b>	

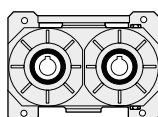

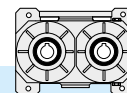

## 6.3 Dati tecnici

## 6.3 Technical data

## 6.3 Technische Daten

Tipo Size Typ			135	150		170		230		
				13	15.5		19		40	
		i	40	7.5	40	40	80	10	28	40
VM	$n_1 = 1400 \text{ min}^{-1}$	$n_2 \text{ [min}^{-1}\text{]}$	35	187	35	35	17.5	140	50	35
		$P_1 \text{ [kW]}$	0.75	1.8	0.75	1.8	1.5	4	4	1.8
		$T_2 \text{ [Nm]}$	66	37	65	160	221	109	268	160
		$F_s$	2	3.7	2.6	1.4	1	3.8	1.6	2.8
VI	$n_1 = 1400 \text{ min}^{-1}$	$n_2 \text{ [min}^{-1}\text{]}$	35	/	/	35	17.5	/	/	/
		$P_1 \text{ [kW]}$	1.5	/	/	2.6	1.5	/	/	/
		$T_2 \text{ [Nm]}$	131	/	/	234	218	/	/	/
		$\eta_D$	0.64	/	/	0.65	0.54	/	/	/
	$n_1 = 900 \text{ min}^{-1}$	$n_2 \text{ [min}^{-1}\text{]}$	23	/	/	23	11	/	/	/
		$P_1 \text{ [kW]}$	1.2	/	/	2	1.1	/	/	/
		$T_2 \text{ [Nm]}$	158	/	/	269	247	/	/	/
		$\eta_D$	0.60	/	/	0.62	0.51	/	/	/
	$n_1 = 500 \text{ min}^{-1}$	$n_2 \text{ [min}^{-1}\text{]}$	12.5	/	/	12.5	6	/	/	/
		$P_1 \text{ [kW]}$	0.8	/	/	1.4	0.8	/	/	/
		$T_2 \text{ [Nm]}$	186	/	/	317	288	/	/	/
		$\eta_D$	0.56	/	/	0.57	0.46	/	/	/
		$\eta_s$	0.43	0.70	0.44	0.45	0.33	0.69	0.49	0.42

 La coppia  $T_2$  è riferita a ciascuna uscita.  $T_2$  torque refers to each output

 $T_2$  bezieht sich auf jedes Abtrieb

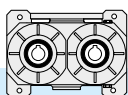

### 6.4 Lubrificazione

Normalmente i riduttori vengono forniti privi di lubrificante. I tappi sono predisposti come da disegno.

### 6.4 Lubrication

The gearboxes are normally supplied without lubricant. The filler plugs are arranged as shown in the drawing.

### 6.4 Schmierung

Normalerweise werden die Getriebe ohne Schmiermittel geliefert. Die Anbringung der Füllstopfen entspricht der Zeichnung.

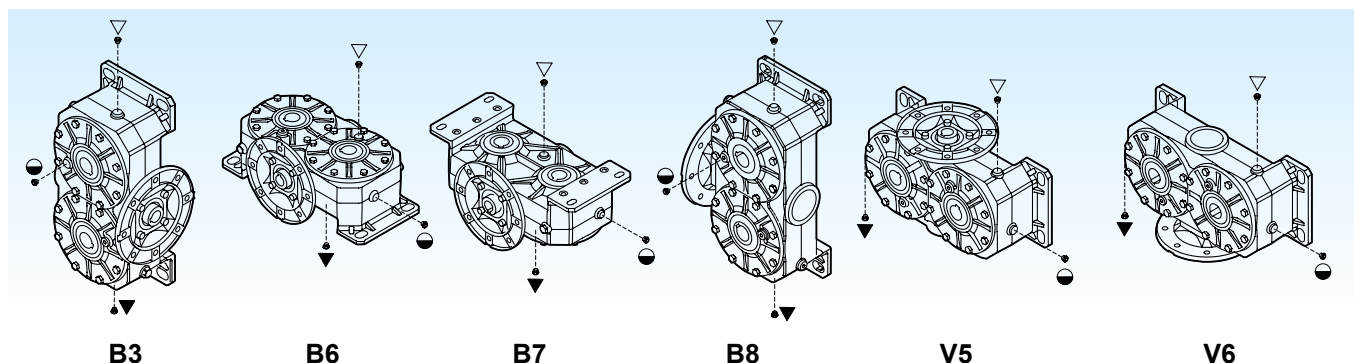

- ▽ Carico e sfiato / Filling and breather  
Einfüll und Entlüftung
- Livello / Level / Ölstand
- ▼ Scarico / Drain / Ablass

		Q.tà olio / Oil quantity / Schmiermittelmenge [lt]				
		Posizione di montaggio / Mounting position / Einbaulage				
		B3	B6	B7	B8	V5 - V6
VM	135	0.8	0.6	0.6	0.8	0.5
	150	1.5	1.2	1.2	1.5	1
	170	2	1.5	1.5	2	1.2
	230	5	4.5	3.5	5	3.2

### 6.5 Carichi radiali e assiali

Nella tabella sono indicati i valori, espressi in N, dei carichi radiali e assiali ammissibili su ogni singola uscita. Il carico radiale  $F_{r2}$  si considera applicato ad una distanza dalla battuta dell'albero cavo pari al valore del diametro. I valori indicati hanno come limite la struttura del riduttore, perciò non variano al diminuire della velocità, cosa che normalmente avviene quando il limite è riferito ai cuscinetti.

### 6.5 Radial and axial loads

In the table, the permissible radial and axial loads for each individual output are shown as N. The radial load  $F_{r2}$  should be considered as applied at a distance from the shaft shoulder equal to the diameter figure. The listed values are limited by the gear drive structure, therefore, they will not change as the speed decreases, which is normally the case when bearings are the limit reference.

### 6.5 Radial und Axial Belastungen

In der Tabelle werden die Werte der auf jedem einzelnen Abtrieb zulässigen Radial- und Axialbelastungen in N angegeben. Hinsichtlich der radialen Belastung  $F_{r2}$  wird von einem Abstand vom Anschlag der Hohlwelle ausgegangen, der dem Wert des Durchmessers entspricht. Die angegebenen Werte werden durch die Struktur des Getriebes beschränkt und verändern sich daher bei Reduzierung der Drehzahl nicht. Dies ist normalerweise dann der Fall, wenn der Grenzwert sich auf die Lager bezieht.

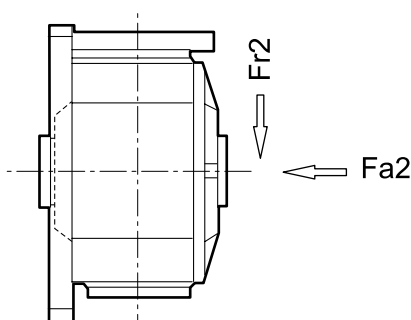

Tipo Size Typ	135	150	170	230
$F_{r2}$ [N]	1200	1900	1700	3000
$F_{a2}$ [N]	600	950	850	1500

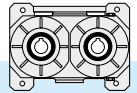

6.6 Dimensioni

6.6 Dimensions

6.6 Abmessungen

135

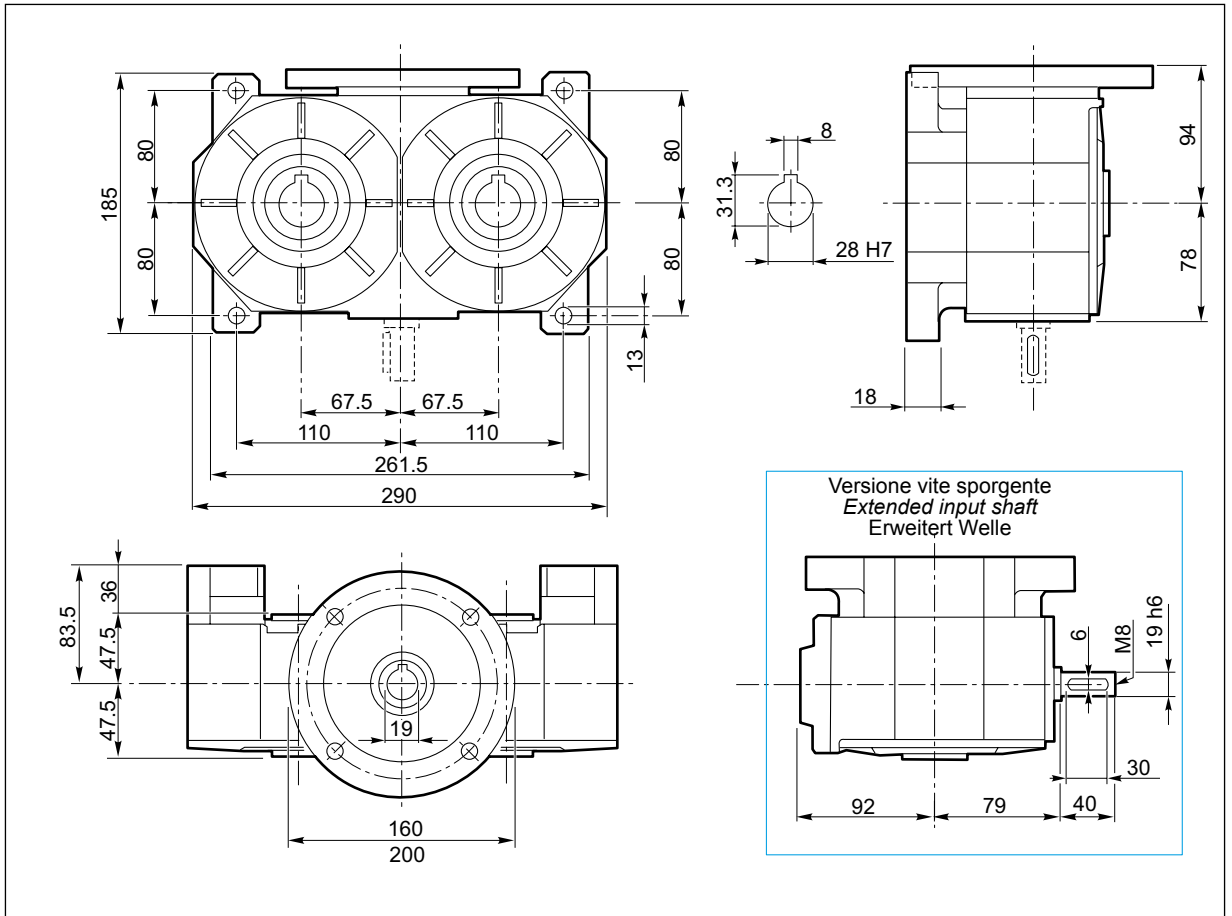

150

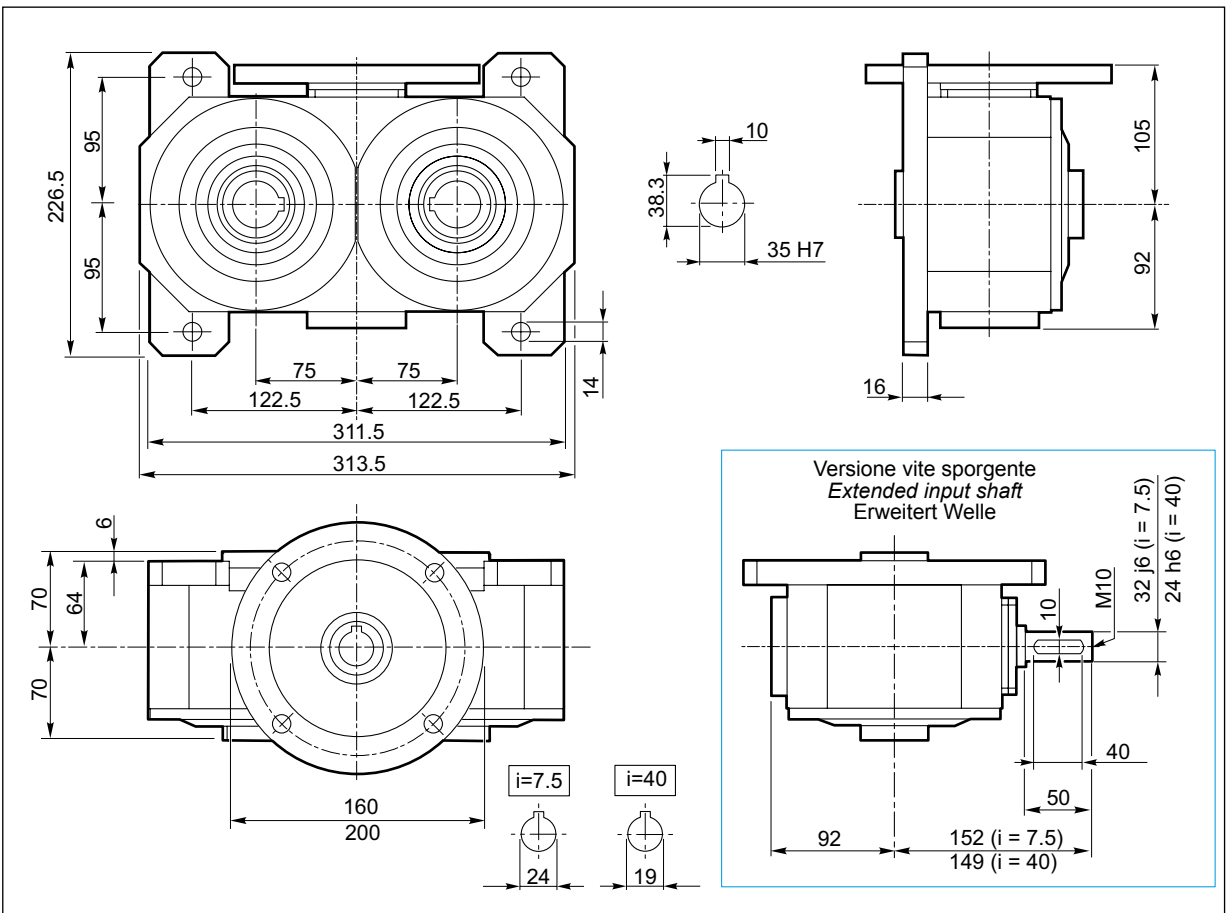

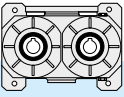

6.6 Dimensioni

6.6 Dimensions

6.6 Abmessungen

170

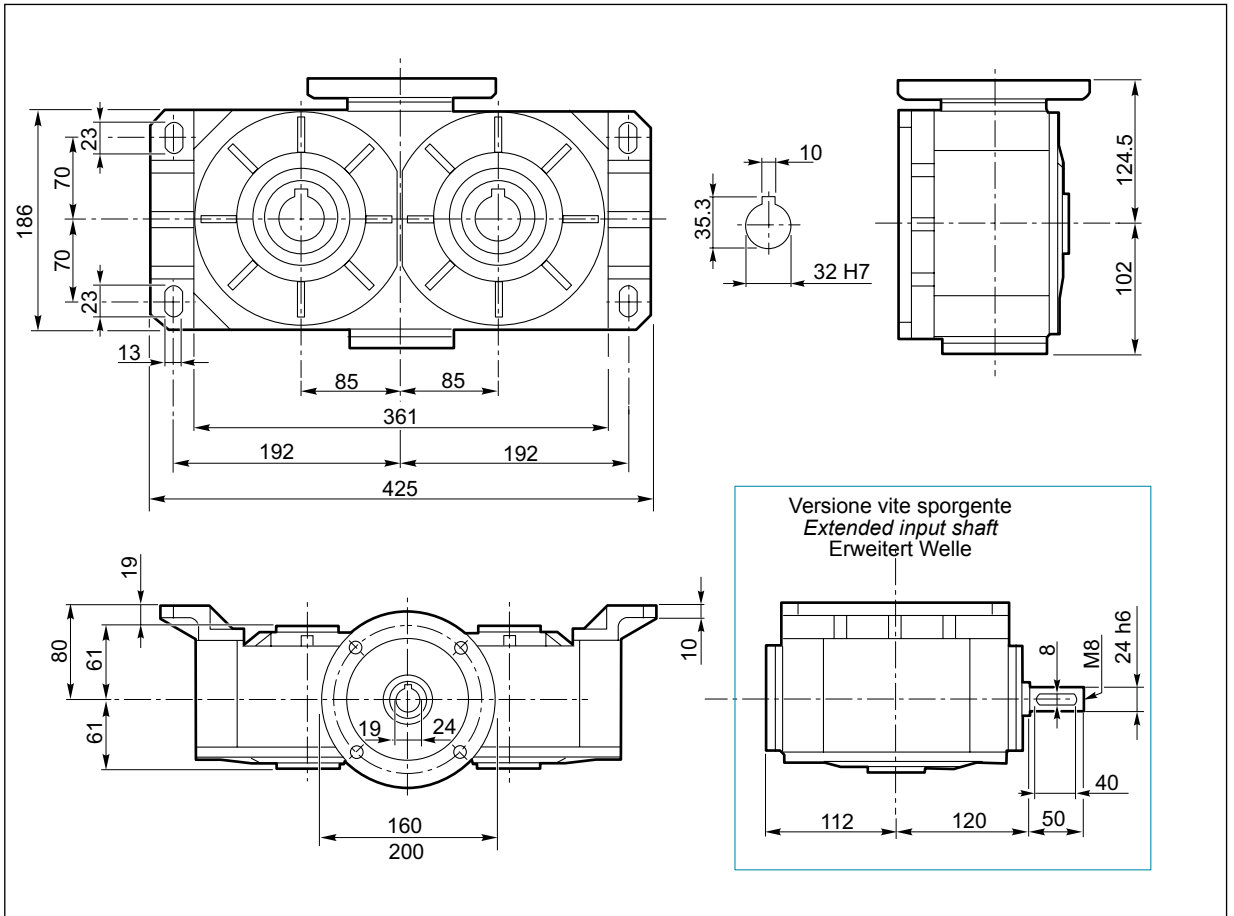

230

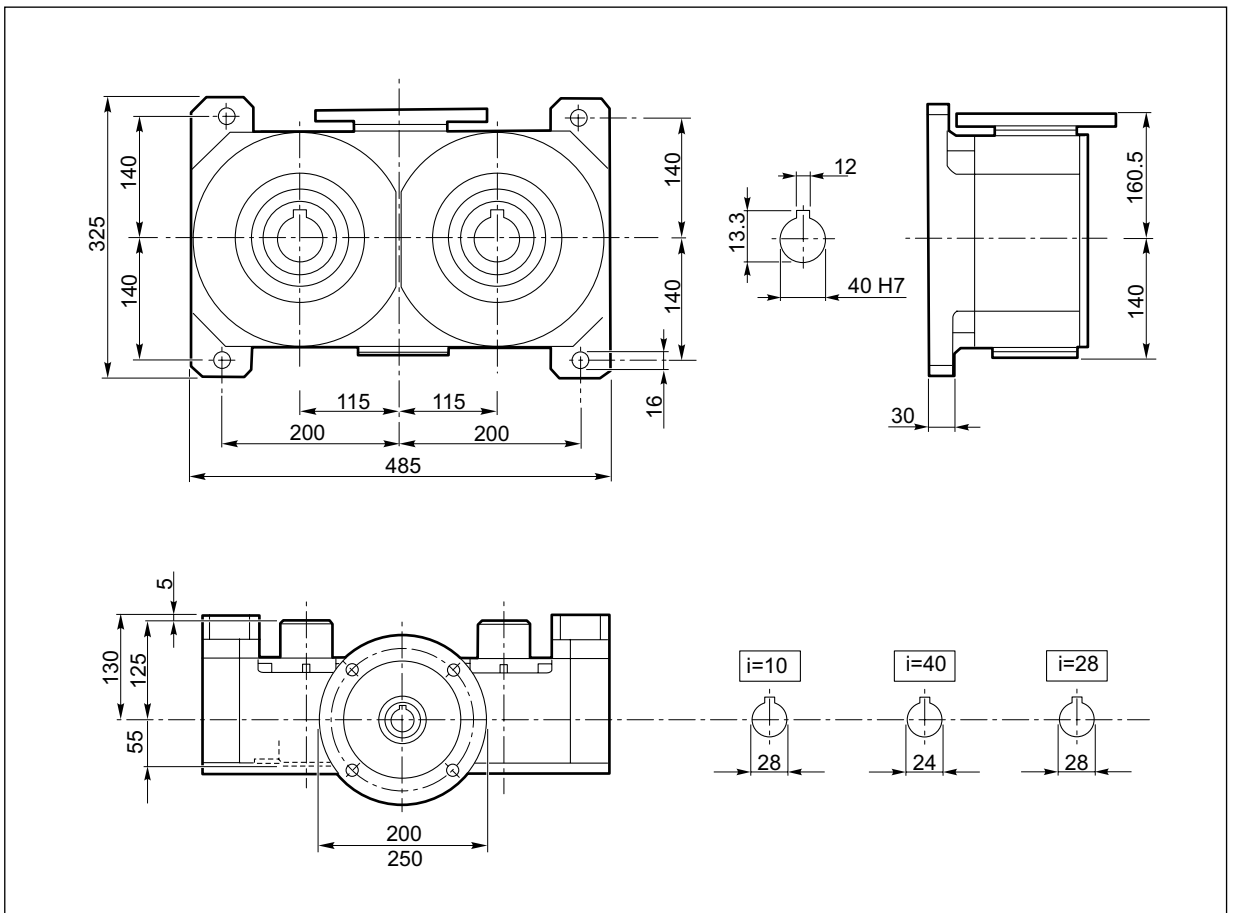

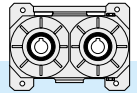

## VM - VI 135

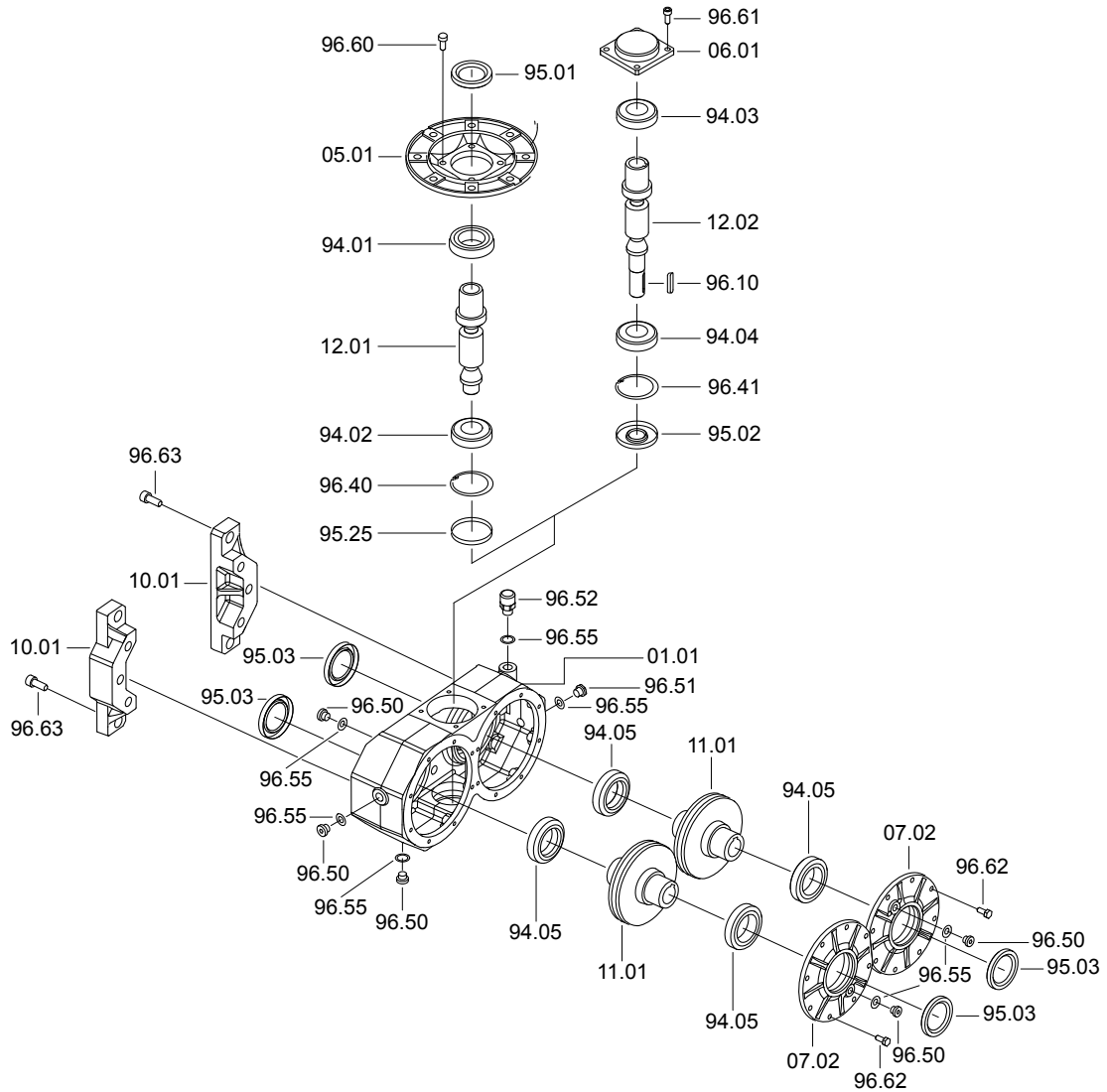

VM VI 135	Cuscinetti / Bearings / Lager					Anelli di tenuta / Oilseals Öldichtungen			Cappellotto / Closed oil seal/ Geschlossene Öldichtung
	94.01	94.02	94.03	94.04	94.05	95.01	95.02	95.03	95.25
	30206 30x62x17.25	30304 20x52x16.25	32010 50x80x20	30206 30x62x17.25	32009 45x75x20	30/56/10	20/52/10	45/65/10	ø 52x7

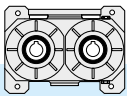

# VM - VI 150

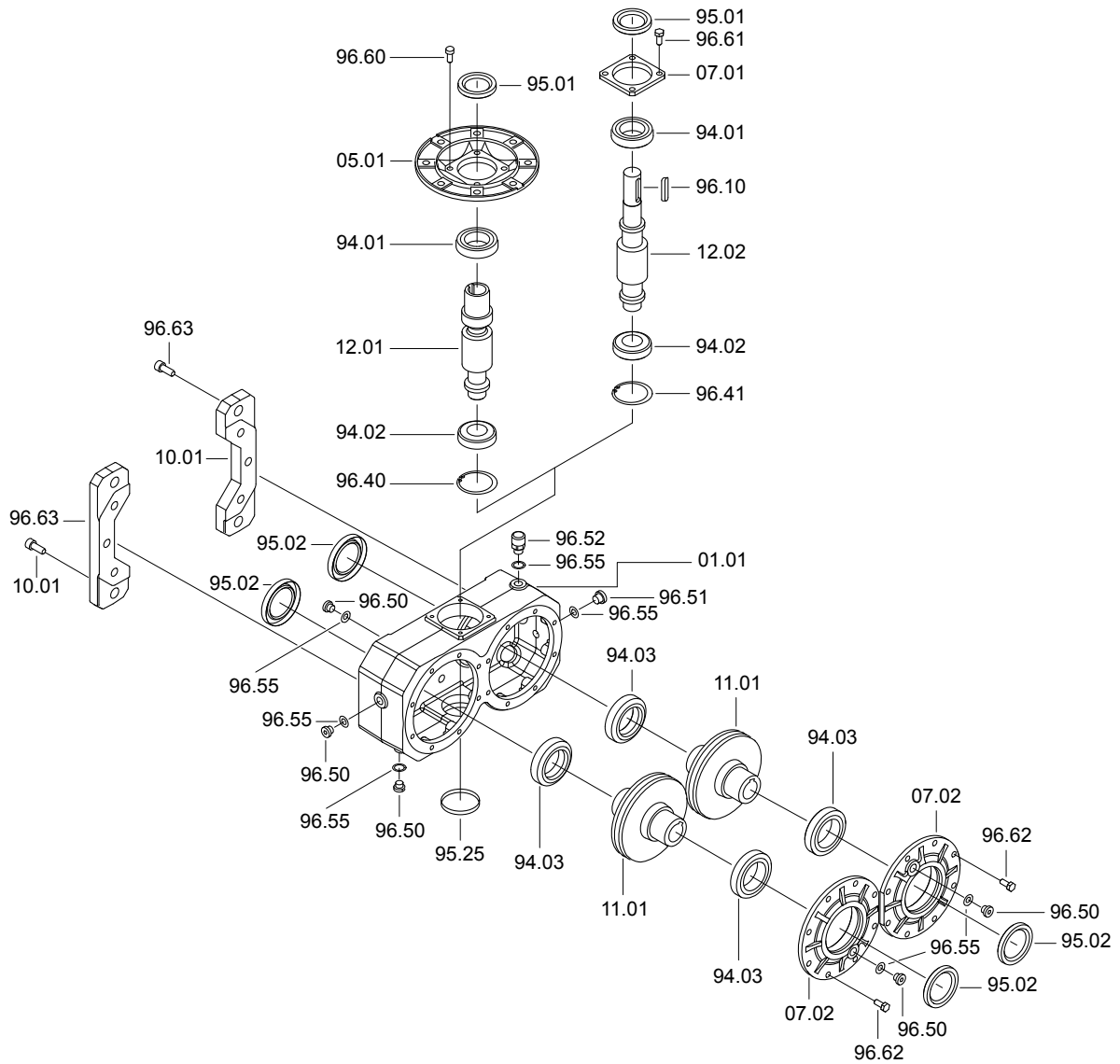

VM VI	Cuscinetti / Bearings / Lager			Anelli di tenuta / Oilseals Öldichtungen		Cappellotto / Closed oil seal Geschlossene Öldichtung
	94.01	94.02	94.03	95.01	95.02	95.25
150	32007 35x62x18	30205 25x52x16.25	32010 50x80x20	35/56/10	50/72/8	ø 52x7
	* 30305 55x62x18					

\* Solo per VI150 i40 / Only for VI150 i40 / Nur für VI150 i40



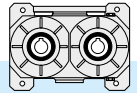

## VM - VI 170

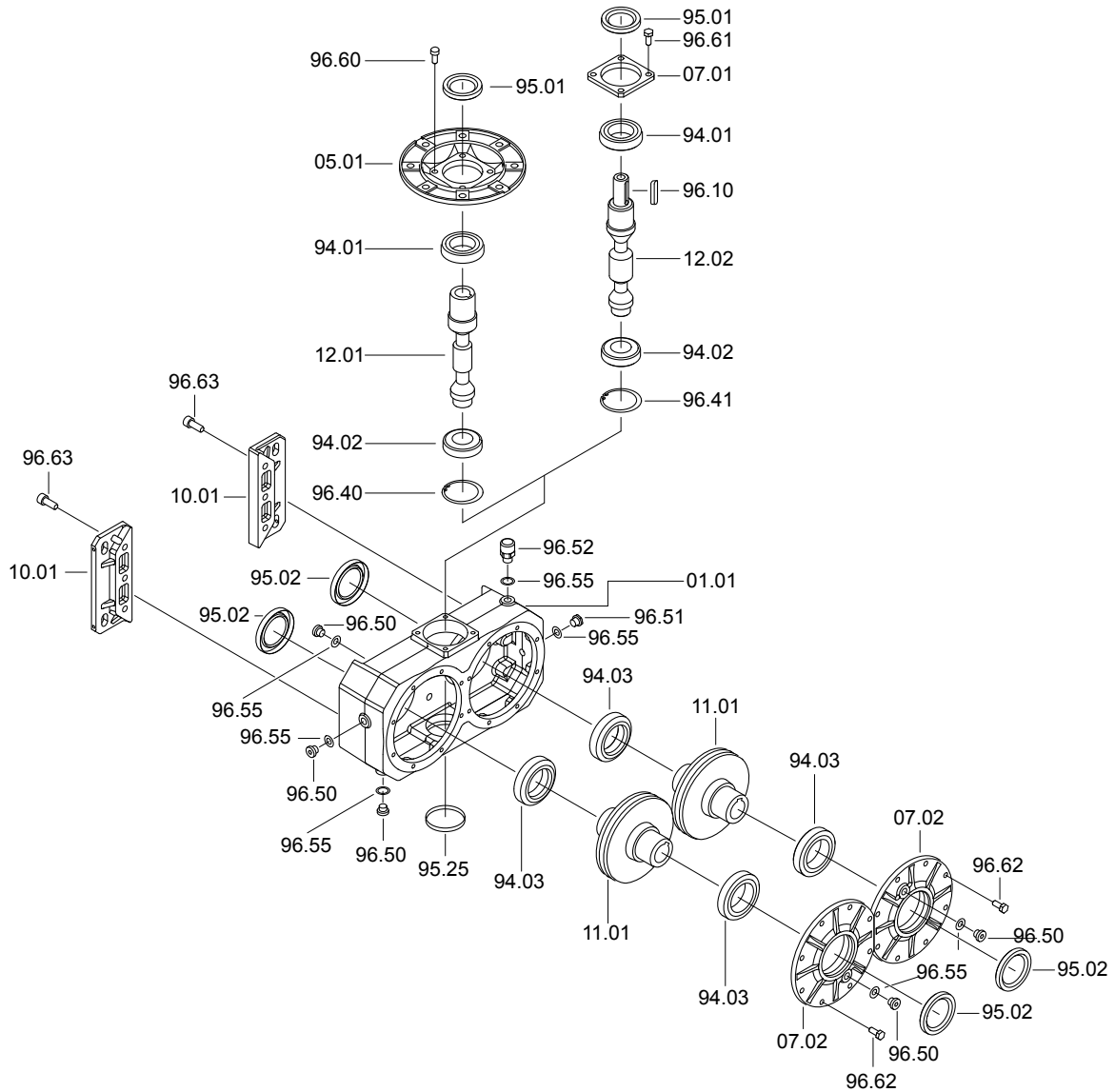

VM VI 170	Cuscinetti / Bearings / Lager			Anelli di tenuta / Oilseals Öldichtungen		Cappellotto / Closed oil seal Geschlossene Öldichtung
	94.01	94.02	94.03	95.01	95.02	95.25
	32008 40x68x19	30206 30x62x17.25	32010 50x80x20	40/62/8	50/72/8	ø 62x7

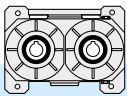

# VM 230

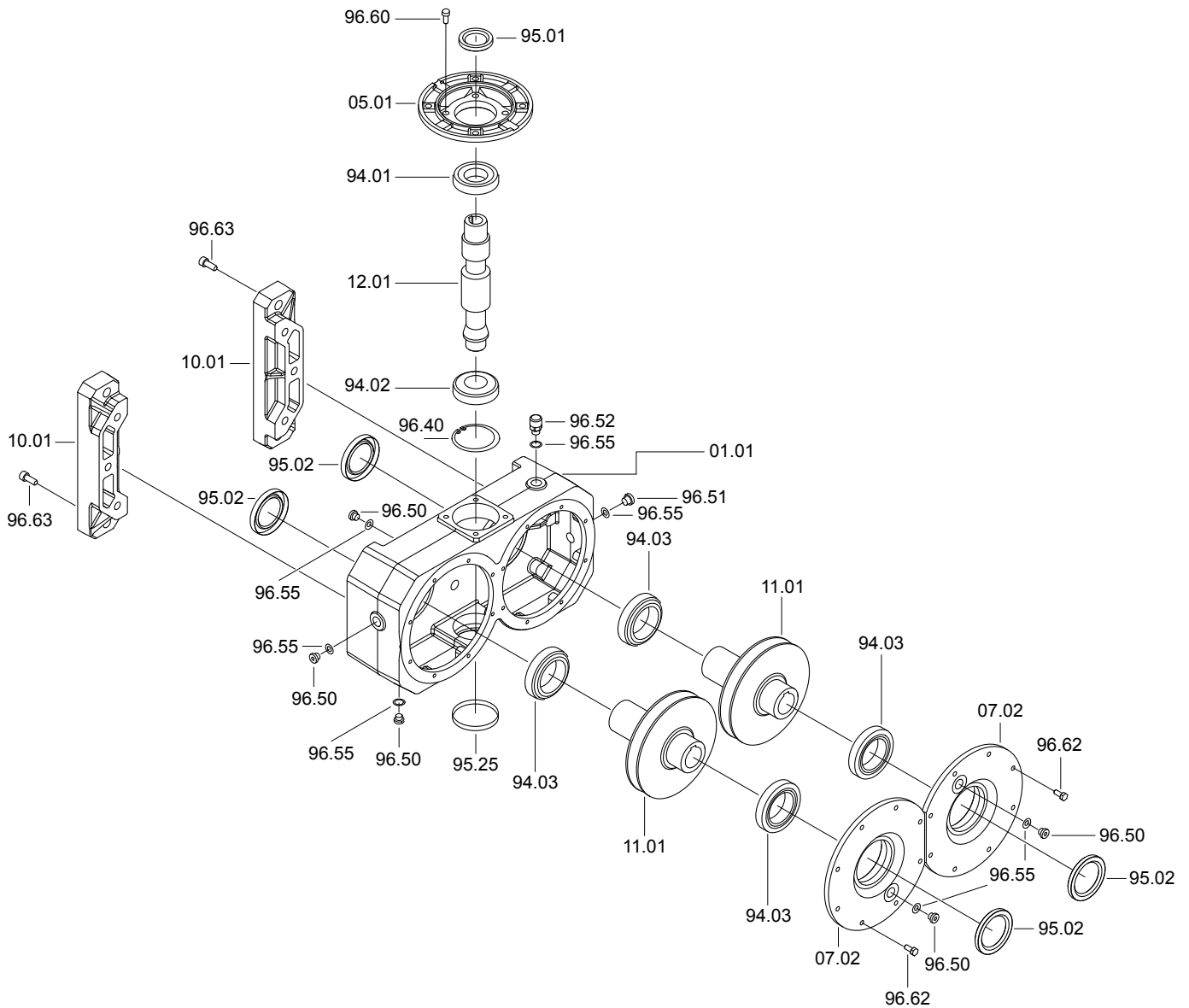

VM	Cuscinetti / Bearings / Lager			Anelli di tenuta / Oilseals Öldichtungen		Cappellotto / Closed oil seal Geschlossene Öldichtung
	94.01	94.02	94.03	95.01	95.02	95.25
<b>230</b>	<b>30208</b> 40x80x19.75	<b>30307</b> 35x80x22.75	<b>32012</b> 60x95x23	40/72/7	60/85/8	ø 80x10