

MOTORI IN CORRENTE CONTINUA
A MAGNETI PERMANENTI

PERMANENT MAGNETS
DIRECT-CURRENT MOTORS

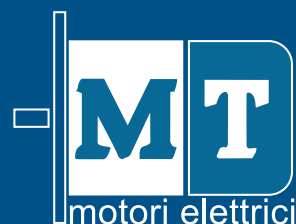

INDICE / INDEX

MOTORI IN C.C. / D.C. MOTORS

Caratteristiche tecniche / Technical specifications.....	2
MPVE.....	4
MPA.....	6
MPT.....	8
MPQ.....	10
MPT35 – MPT60.....	11
MPL.....	12
MPR.....	14
Flange / Flanges.....	15

MOTORIDUTTORI MR / GEAR MOTORS MR

Descrizione / Description.....	16
MR25DC.....	17
MR65DC.....	18
MR25AC.....	20

AZIONAMENTI / D.C. MOTOR CONTROLS

Descrizione / Description.....	22
--------------------------------	----

RIDUTTORI EPICICLOIDALI / PLANETARY GEAR UNITS.....	L1-L18
---	--------

CARATTERISTICHE TECNICHE

I nostri motori in corrente continua a magneti permanenti sono prodotti di serie con attacchi unificati IEC, a richiesta possiamo realizzarli con attacchi non unificati.

Tutti i motori riportati nel presente catalogo sono costruiti con magneti permanenti, hanno perciò due soli morsetti impegnati in morsettiera. La regolazione della velocità di rotazione si ottiene variando opportunamente la tensione di armatura. L'inversione del senso di marcia si ottiene invertendo la polarità della tensione di alimentazione, operazione da effettuarsi esclusivamente ad indotto fermo per non danneggiare il motore.

Nei motori autoventilati (MPVE – MPA) riducendo la velocità di rotazione si riduce l'efficacia del raffreddamento, perciò, affinché le condizioni termiche di lavoro non diventino pericolose per la vita del motore, è necessario declassare i valori nominali (C%) in funzione della riduzione della velocità di rotazione che si intende operare (F) secondo il grafico seguente:

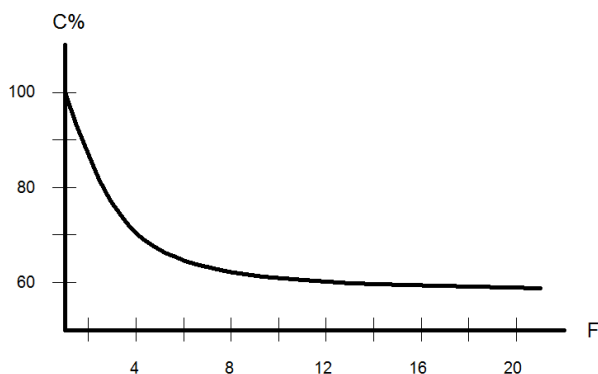

Se il servizio al quale il motore viene adibito è differente da quello di riferimento per i dati riportati sul presente catalogo, dal grafico seguente è possibile rilevare le prestazioni che esso può fornire in tali condizioni. Il grafico rappresenta la curva isoterma, riferita alla temperatura ambiente di 25°C e ad un ciclo di lavoro della durata pari alla costante di tempo termica del motore (CTT), descritta dalla percentuale di coppia nominale erogabile (C%) in funzione della durata del ciclo di lavoro (S%), espressa come percentuale della CTT del motore:

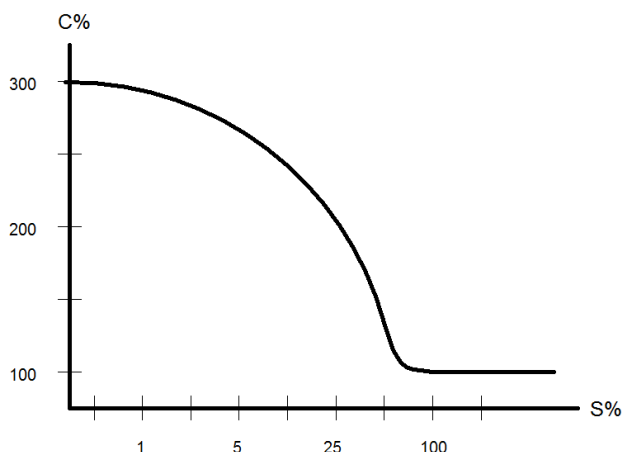

TECHNICAL SPECIFICATIONS

The direct current permanent magnets motors shown in the catalogue are supplied with foot mounting, flanges and shaft to standard IEC dimensions. Special shaft or flanges are available on request.

The motors shown in the catalogue are supplied with permanent magnets, so their terminal box has got only two terminals.

Rotation speed of the motor can be varied using a suitable controller.

Direction of rotation can be changed reversing the polarity, but it is important to ensure that the motor shaft has stopped before reversing.

The MPVE and MPA series are self ventilated and therefore as the speed decreases the cooling becomes less effective. To ensure that the motor runs within its temperature limits, the rated value (C%) should be derated in line with the speed required (F) as shown in the following graph:

C% = PERCENTUALE DI COPPIA NOMINALE
= PERCENTAGE OF RATED TORQUE

F = RPMmax/RPMmin

Should the motor be required for a different duty from the ones specified in this catalogue, the performance levels possible are shown in the graph below. This represents the isothermal curve based on an ambient of 25°C and a duty cycle equal to the thermal time constant of the motor (CTT), this is calculated by the percentage of rated torque achieved (C%), base on the duty time (S%) expressed as a percentage of the CTT:

C% = PERCENTUALE DI COPPIA NOMINALE
= PERCENTAGE OF RATED TORQUE

S% = DURATA DEL SERVIZIO IN PERCENTUALE DI CTT
= DUTY CYCLE PERCENTAGE OF CTT

I dati riportati sul presente catalogo sono stati rilevati, alimentando i motori con azionamenti a ponte semicontrolato (SCR), sono quindi riferiti ad un fattore di forma (FF) dell'onda di tensione di alimentazione pari a 1,4. Per valori differenti di FF, le prestazioni erogabili dal motore (C%), espresse come percentuale della coppia nominale, possono essere rilevate sul grafico seguente:

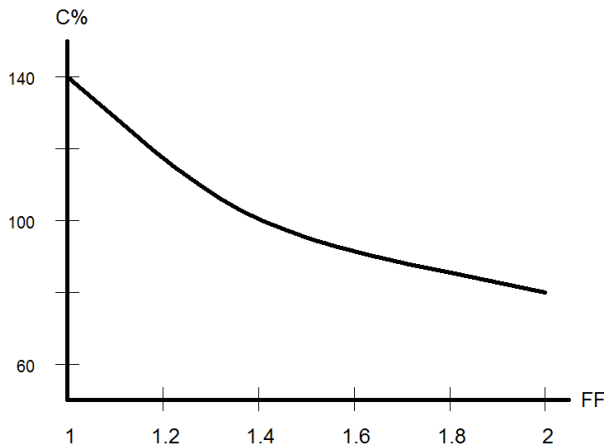

MPA

I motori della serie MPA sono realizzati con magneti permanenti ceramici ed autoventilati con protezione IP23, perciò adatti all'impiego in ambienti privi di polvere ed umidità. I valori nominali di questi motori si intendono resi all'albero per servizio 100% (S1).

MPVE – MR25AC

I motori delle serie MPVE e MR25AC sono realizzati con magneti permanenti ceramici ed autoventilati con protezione IP54 (a richiesta IP55), perciò sono adatti all'impiego in quasi ogni tipo di ambiente. I valori nominali di questi motori si intendono resi all'albero per servizio 100% (S1).

MPT – MPQ – MPL – MPT35 – MPT60 MPR – MR25DC – MR65DC

I motori delle serie MPT, MPQ, MPL, MPT35, MPT60, MR25DC e MR65DC sono realizzati con magneti permanenti ceramici, i motori della serie MPR con magneti permanenti in Neodimio (NeFeB), sono tutti privi di ventilazione. I valori nominali si intendono resi all'albero per servizio intermittente 50% con durata del ciclo pari alla CTT (S2). Per servizio continuativo (S1) devono essere declassati del 40%. Alcuni di essi, a richiesta, possono essere dotati di ventilazione, in tal caso i valori nominali si intendono resi all'albero per servizio 100% (S1).

I motori MPT ed MPQ hanno protezione IP54 (a richiesta IP55 e IP65); i motori MPL, MPT35, MPT60, MPR, MR25DC e MR65DC hanno protezione IP44 perciò adatti all'impiego in quasi ogni tipo di ambiente.

Per esecuzioni non riportate sul presente catalogo contattare il nostro Ufficio tecnico od il nostro Agente di Zona.

Le dimensioni e caratteristiche dei prodotti riportati sul presente catalogo sono da ritenersi indicative e possono essere modificate in qualsiasi momento per esigenze tecniche.

Il presente catalogo sostituisce e annulla i precedenti.

The performance details as shown in this catalogue have been obtained supplying the motors by SCR speed controls, therefore they refer to a form factor (FF) of the feeding voltage wave equal to 1.4. The performance reached by the motor (C%) with different values, expressed as percentage of the rated torque, may be detected in the following graph:

C%

= PERCENTUALE DI COPPIA NOMINALE
= PERCENTAGE OF RATED TORQUE

FF

= FATTORE DI FORMA
= FORM FACTOR

MPA

The MPA type motors are self-ventilated and equipped with IP23 mechanical protection. Therefore, they can be used only in humidity or dust free room. The rated data for these motors are to be intended yielded to the shaft for duty 100% (S1).

MPVE – MR25AC

The MPVE and MR25AC motors are self-ventilated and equipped with IP54 (IP 55 on request) mechanical protection. Therefore, they can be used almost in every kind of rooms. The rated data for these motors are to be intended yielded to the shaft for duty 100% (S1).

MPT – MPQ – MPL – MPT35 – MPT60 MPR – MR25DC – MR65DC

The MPT, MPQ, MPL, MPT35, MPT60, MR25DC and MR65DC motors are constructed with ferrite permanent magnets, the MPR motors with Neodymium permanent magnets, without fan. The rated data for these motors are to be intended yielded to the shaft for duty 50% for duty cycle equal to CTT (S2), for duty 100% (S1) they have to derated by 40%. On request, it is possible to supply some of them with fan, in this case the rated data are to be intended yielded to the shaft for duty 100% (S1).

The MPT and MPQ motors are equipped with IP54 (IP 55 or IP65 on request) mechanical protection and MPL, MPT35, MPT60, MPR, MR25DC and MR65DC motors are equipped with IP44 mechanical protection. Therefore, they can be used almost in every kind of rooms.

Please contact your Local Agent/Distributor or our Technical Office with any special requirements you may have which are not covered in this catalogue.

All informations supplied in this catalogue are not binding and are subject to change without notice

This catalogue replaces and makes all previous ones void.

MPVE

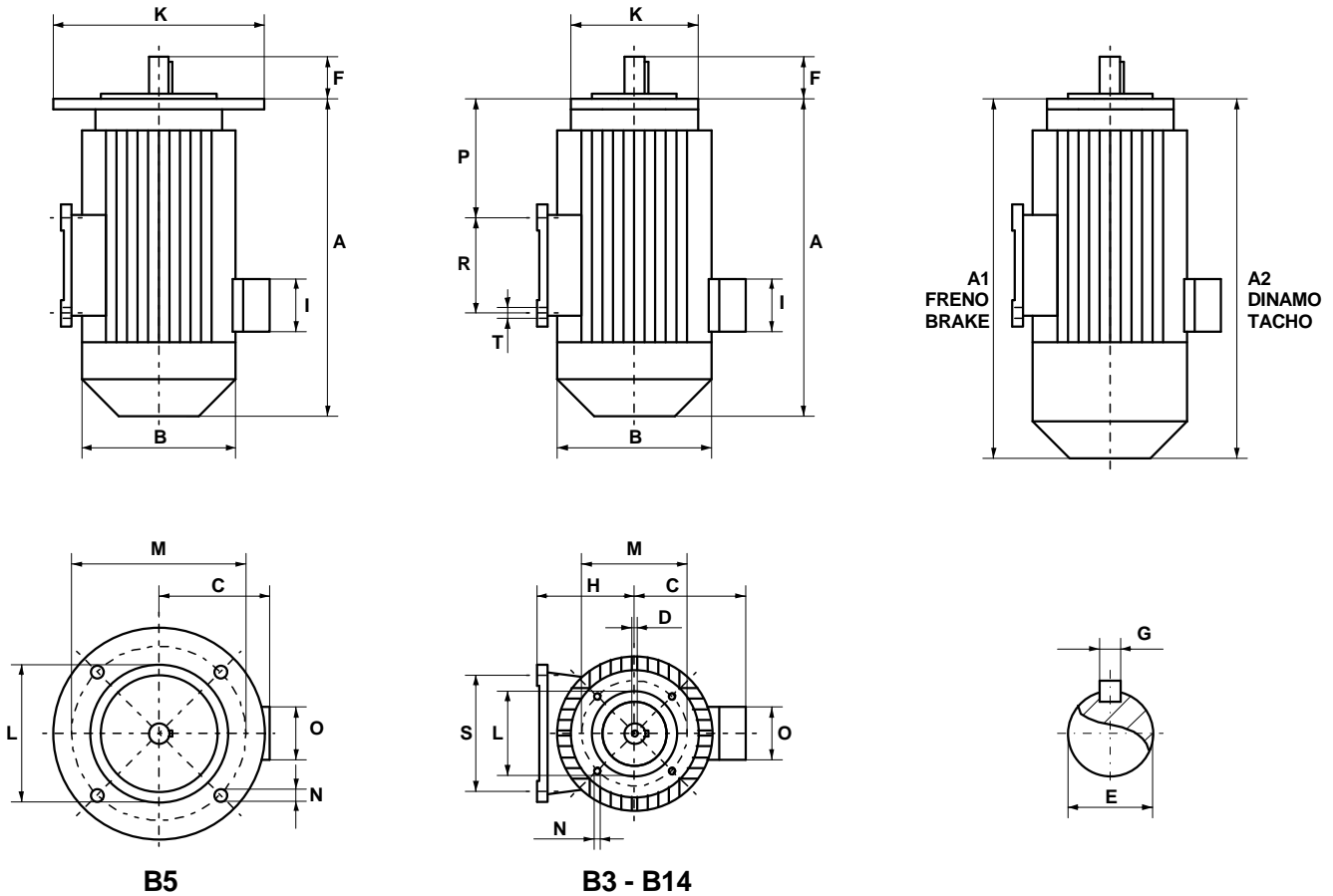

MPVE	INGOMBRO DIMENSIONS						ALBERO SHAFT			FLANGIA B5 FLANGE B5				FLANGIA B14 FLANGE B14				B3						PESO WEIGHT	
	A	B	C	I	O	A1	A2	E	F	G	K	L	M	N	K	L	M	N	D	H	P	R	S		T
56	175	110	90	71	71	219	255	9	18	3	120	80	100	7	80	50	65	M5	M4	63	30	80	100	9	2.7
56L	187	110	90	71	71	231	267	9	18	3	120	80	100	7	80	50	65	M5	M4	63	36	80	100	9	3.3
63	220	110	90	71	71	264	300	11	23	4	140	95	115	9	90	60	75	M5	M4	63	52	80	100	9	4.7
63L	275	110	90	71	71	319	355	11	23	4	140	95	115	9	90	60	75	M5	M4	63	74	80	100	9	6
71C	209	138	109	71	71	259	289	14	30	5	160	110	130	9	105	70	85	M6	M5	80	46	80	112	9	5.5
71	262	138	109	71	71	312	342	14	30	5	160	110	130	9	105	70	85	M6	M5	80	68	90	112	9	9
80	285	158	116	71	71	342	365	19	40	6	200	130	165	11	120	80	100	M6	M6	90	88	100	125	11	12
80L	321	158	116	71	71	378	401	19	40	6	200	130	165	11	120	80	100	M6	M6	90	106	100	125	11	15

MPVE

MPVE	V	1500rpm		2000rpm		2400rpm		3000rpm		COPPIA TORQUE	CTT
		W	A	W	A	W	A	W	A		
56	12	70	7.5	95	10	110	11.7	140	15	Nm 0.46	Min' 45
	24	70	3.5	95	4.8	110	6	140	8		
	48	70	1.8	95	2.4	110	3	140	4		
	90	70	1	95	1.4	110	1.6	140	2		
	170	70	0.55	95	0.75	110	0.9	140	1.1		
56L	12	100	10.7	135	14.4	160	17	200	21.4	Nm 0.65	Min' 45
	24	100	5.4	135	7.2	160	8.5	200	10.7		
	48	100	2.7	135	3.6	160	4.3	200	5.4		
	90	100	1.4	135	1.9	160	2.3	200	2.9		
	170	100	0.75	135	1	160	1.2	200	1.5		
63	12	150	16	200	21.4	240	25.6			Nm 0.98	Min' 45
	24	150	8	200	10.7	240	12.8	300	16		
	48	150	4	200	5.3	240	6.4	300	8		
	90	150	2.1	200	2.8	240	3.4	300	4.3		
	170	150	1.1	200	1.5	240	1.8	300	2.4		
63L	12	200	21.5	265	28.4					Nm 1.30	Min' 45
	24	200	10.7	265	14.2	320	17.2	400	21.5		
	48	200	5.4	265	7.1	320	8.5	400	10.7		
	90	200	2.9	265	3.8	320	4.6	400	5.7		
	170	200	1.5	265	2	320	2.1	400	3		
71C	12	175	18.6	235	25	280	30	350	37	Nm 1.14	Min' 60
	24	175	9.3	235	12.5	280	15	350	18.7		
	48	175	4.7	235	6.3	280	7.5	350	9.4		
	90	175	2.5	235	3.3	280	4	350	5		
	170	175	1.3	235	1.8	280	1.8	350	2.8		
71	12	300	32							Nm 1.96	Min' 60
	24	300	16	400	22	480	25.6	600	32		
	48	300	8	400	11	480	12.8	600	16		
	90	300	4.3	400	5.8	480	6.9	600	8.7		
	170	300	2.3	400	3.1	480	3.7	600	4.6		
80	12	450	48							Nm 2.94	Min' 60
	24	450	24	600	32	720	38.4	900	48		
	48	450	12	600	16	720	19.2	900	24		
	90	450	6.4	600	8.6	720	10.2	900	12.8		
	170	450	3.4	600	4.5	720	5.5	900	6.8		
80L	12									Nm 3.92	Min' 60
	24	600	33	800	42.8						
	48	600	16.5	800	21.4	960	26.4	1200	33		
	90	600	8.5	800	11.4	960	13.6	1200	17		
	170	600	4.6	800	6	960	7.2	1200	9		

MPA

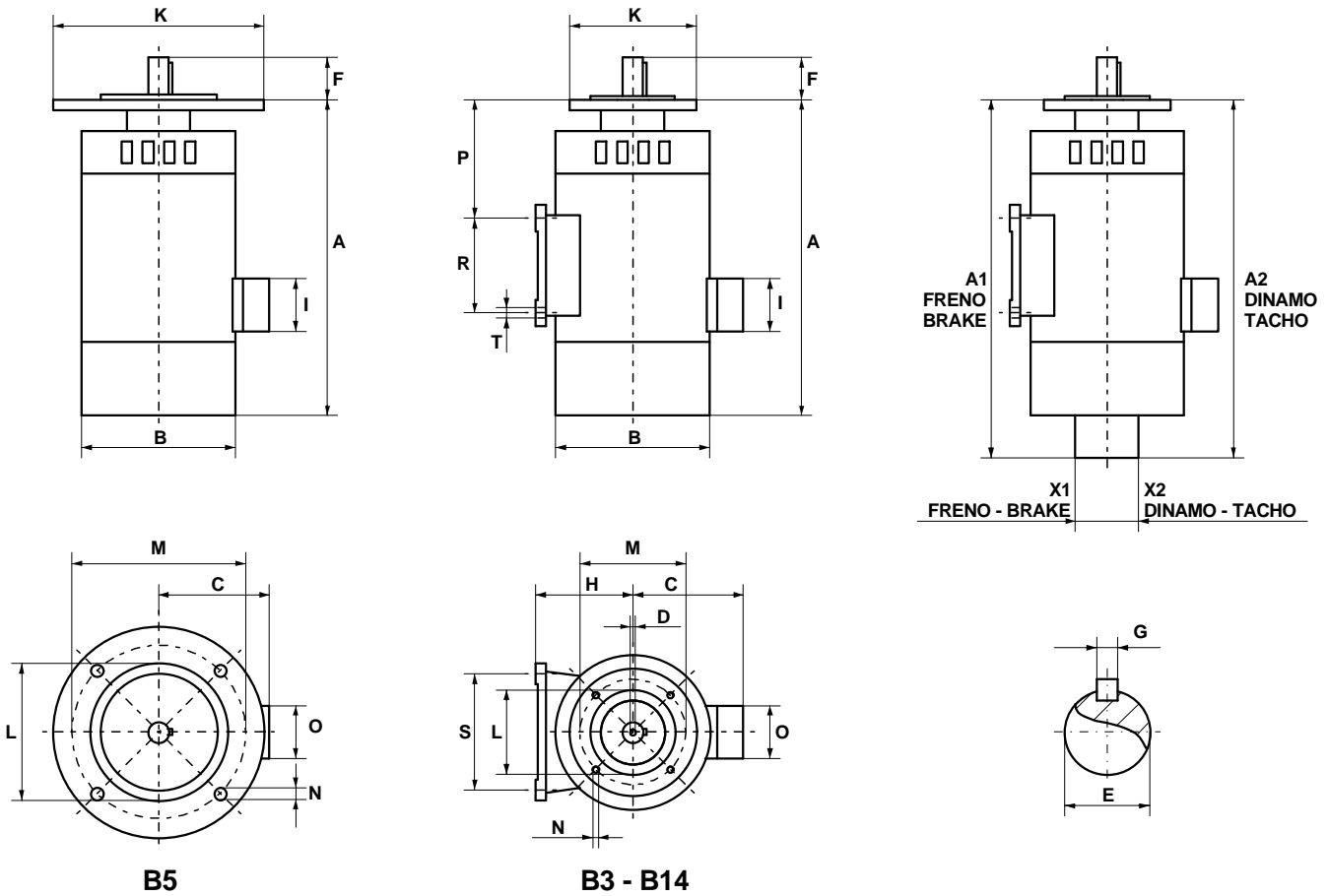

MPA	INGOMBRO DIMENSIONS									ALBERO SHAFT			FLANGIA B5 FLANGE B5				FLANGIA B14 FLANGE B14				B3						PESO WEIGHT KG
	A	B	C	I	O	A1	X1	A2	X2	E	F	G	K	L	M	N	K	L	M	N	D	H	P	R	S	T	
56	184	110	91	61	61	228	59	264	65	9	18	3	120	80	100	7	80	50	65	M5	M4	70	43	85	85	6	3.1
63	223	126	99	61	61	267	59	303	65	11	23	4	140	95	115	9	90	60	75	M5	M4	77	62	90	112	9	5.2
71	260	146	109	61	61	310	87	340	65	14	30	5	160	110	130	9	105	70	85	M6	M5	92	89	90	112	9	8.5
80	296	146	109	61	61	353	105	376	65	19	40	6	200	130	165	11	120	80	100	M6	M6	92	108	90	112	9	11

MPA

MPA	V	1500rpm		2000rpm		2400rpm		3000rpm		COPPIA TORQUE	CTT
		W	A	W	A	W	A	W	A		
56	12	70	7.5	95	10	110	11.7	140	15	Nm 0.46	Min' 45
	24	70	3.5	95	4.8	110	6	140	8		
	48	70	1.8	95	2.4	110	3	140	4		
	90	70	1	95	1.4	110	1.6	140	2		
	170	70	0.55	95	0.75	110	0.9	140	1.1		
63	12	150	16	200	21.4	240	25.6	300	32	Nm 0.98	Min' 45
	24	150	8	200	10.7	240	12.8	300	16		
	48	150	4	200	5.3	240	6.4	300	8		
	90	150	2.1	200	2.8	240	3.4	300	4.3		
	170	150	1.1	200	1.5	240	1.8	300	2.4		
71	12	250	26.7	330	35	400	42.7	500	53.4	Nm 1.63	Min' 60
	24	250	13.3	330	17.6	400	21.4	500	26.7		
	48	250	6.7	330	8.8	400	10.7	500	13.5		
	90	250	3.6	330	4.7	400	5.7	500	7.1		
	170	250	1.9	330	2.5	400	3	500	3.8		
80	12	450	48	600	64					Nm 2.91	Min' 60
	24	450	24	600	32	710	38	890	47.5		
	48	450	12	600	16	710	19	890	23.8		
	90	450	6.4	600	8.5	710	11.1	890	12.7		
	170	450	3.4	600	4.6	710	5.3	890	6.7		

MPT

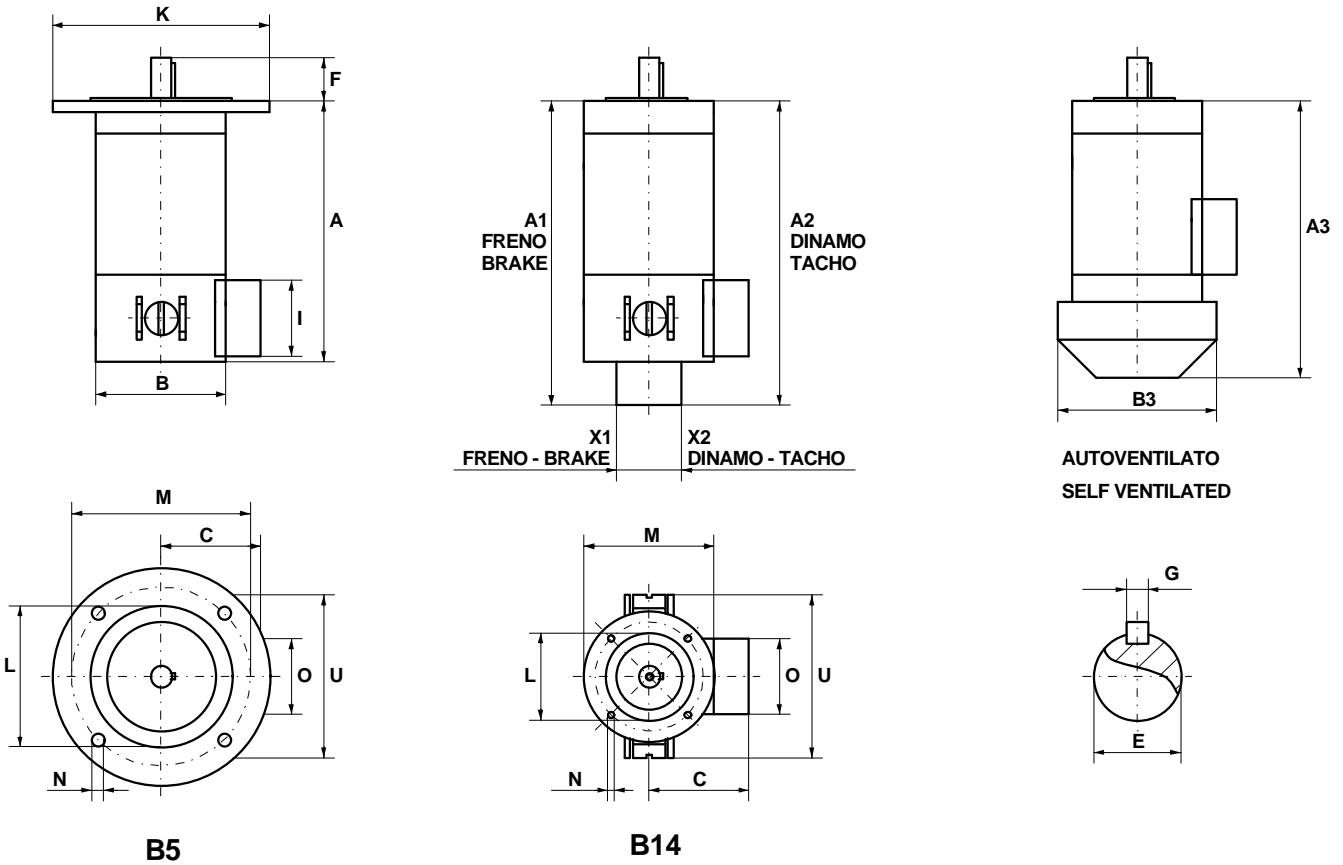

MPT	INGOMBRO DIMENSIONS												ALBERO SHAFT			FLANGIA B5 FLANGE B5				FLANGIA B14 FLANGE B14				PESO WEIGHT
	A	B	C	I	O	U	A1	X1	A2	X2	A3	B3	E	F	G	K	L	M	N	K	L	M	N	KG
40	139	80	78	29	29	106	183	59	219	65	165	110	9	18	3	120	80	100	7	80	50	65	M5	2
50	149	80	78	29	29	106	193	59	229	65	175	110	9	18	3	120	80	100	7	80	50	65	M5	2.3
65	161	80	78	29	29	106	205	59	241	65	187	110	9	18	3	120	80	100	7	80	50	65	M5	2.7
80	174	80	78	29	29	106	218	59	254	65	200	110	9	18	3	120	80	100	7	80	50	65	M5	3.1
100	194	80	78	29	29	106	238	59	274	65	220	110	11	23	4	140	95	115	9	90	60	75	M5	3.7
150	249	80	78	29	29	106	293	59	329	65	275	110	11	23	4	140	95	115	9	90	60	75	M5	4.8
201	184	105	84	71	71	136	234	87	264	65			14	30	5	160	110	130	9	105	70	85	M6	4.5
201	237	105	84	71	71	136	287	87	317	65			14	30	5	160	110	130	9	105	70	85	M6	7
203	248	120	92	71	71	150	305	105	328	65			19	40	6	200	130	165	11	120	80	100	M6	10
204	284	120	92	71	71	150	341	105	364	65			19	40	6	200	130	165	11	120	80	100	M6	12

MPT

MPT	V	1500rpm		2000rpm		2400rpm		3000rpm		COPPIA TORQUE	CTT
		W	A	W	A	W	A	W	A		
40	12	50	5.5	67	7.3	80	8.8	100	11	Nm 0.33	Min' 45
	24	50	2.7	67	3.6	80	4.4	100	5.5		
	48	50	1.4	67	1.8	80	2.2	100	2.7		
	90	50	0.73	67	0.97	80	1.16	100	1.45		
	170	50	0.39	67	0.50	80	0.62	100	0.77		
50	12	70	7.5	95	10	110	11.7	140	15	Nm 0.46	Min' 45
	24	70	3.5	95	4.8	110	6	140	8		
	48	70	1.8	95	2.4	110	3	140	4		
	90	70	1	95	1.4	110	1.6	140	2		
	170	70	0.55	95	0.75	110	0.9	140	1.1		
65	12	100	10.7	135	14.4	160	17	200	21.4	Nm 0.65	Min' 45
	24	100	5.4	135	7.2	160	8.5	200	10.7		
	48	100	2.7	135	3.6	160	4.3	200	5.4		
	90	100	1.4	135	1.9	160	2.3	200	2.9		
	170	100	0.75	135	1	160	1.2	200	1.5		
80	12	125	13.5	165	18	200	21.5	250	27	Nm 0.65	Min' 45
	24	125	6.7	165	9	200	10.8	250	13.5		
	48	125	3.4	165	4.5	200	5.4	250	6.7		
	90	125	1.8	165	2.4	200	2.9	250	3.6		
	170	125	0.95	165	1.3	200	1.5	250	1.9		
100	12	150	16	200	21.4	240	25.6	300	32	Nm 0.98	Min' 45
	24	150	8	200	10.7	240	12.8	300	16		
	48	150	4	200	5.3	240	6.4	300	8		
	90	150	2.1	200	2.8	240	3.4	300	4.3		
	170	150	1.1	200	1.5	240	1.8	300	2.4		
150	12	200	21.5	265	28.4					Nm 1.30	Min' 45
	24	200	10.7	265	14.2	320	17.2	400	21.5		
	48	200	5.4	265	7.1	320	8.5	400	10.7		
	90	200	2.9	265	3.8	320	4.6	400	5.7		
	170	200	1.5	265	2	320	2.1	400	3		
201	12	175	18.6	235	25	280	30	350	37	Nm 1.14	Min' 60
	24	175	9.3	235	12.5	280	15	350	18.7		
	48	175	4.7	235	6.3	280	7.5	350	9.4		
	90	175	2.5	235	3.3	280	4	350	5		
	170	175	1.3	235	1.8	280	1.8	350	2.8		
202	12	300	32							Nm 1.96	Min' 60
	24	300	16	400	22	480	25.6	600	32		
	48	300	8	400	11	480	12.8	600	16		
	90	300	4.3	400	5.8	480	6.9	600	8.7		
	170	300	2.3	400	3.1	480	3.7	600	4.6		
203	48	450	12	600	16	720	19.2	900	24	Nm 2.94	Min' 60
	90	450	6.4	600	8.6	720	10.2	900	12.8		
	170	450	3.4	600	4.5	720	5.5	900	6.8		
204	48	600	16.5	800	21.4	960	26.4	1200	33	Nm 3.92	Min' 60
	90	600	8.5	800	11.4	960	13.6	1200	17		
	170	600	4.6	800	6	960	7.2	1200	9		

MPQ

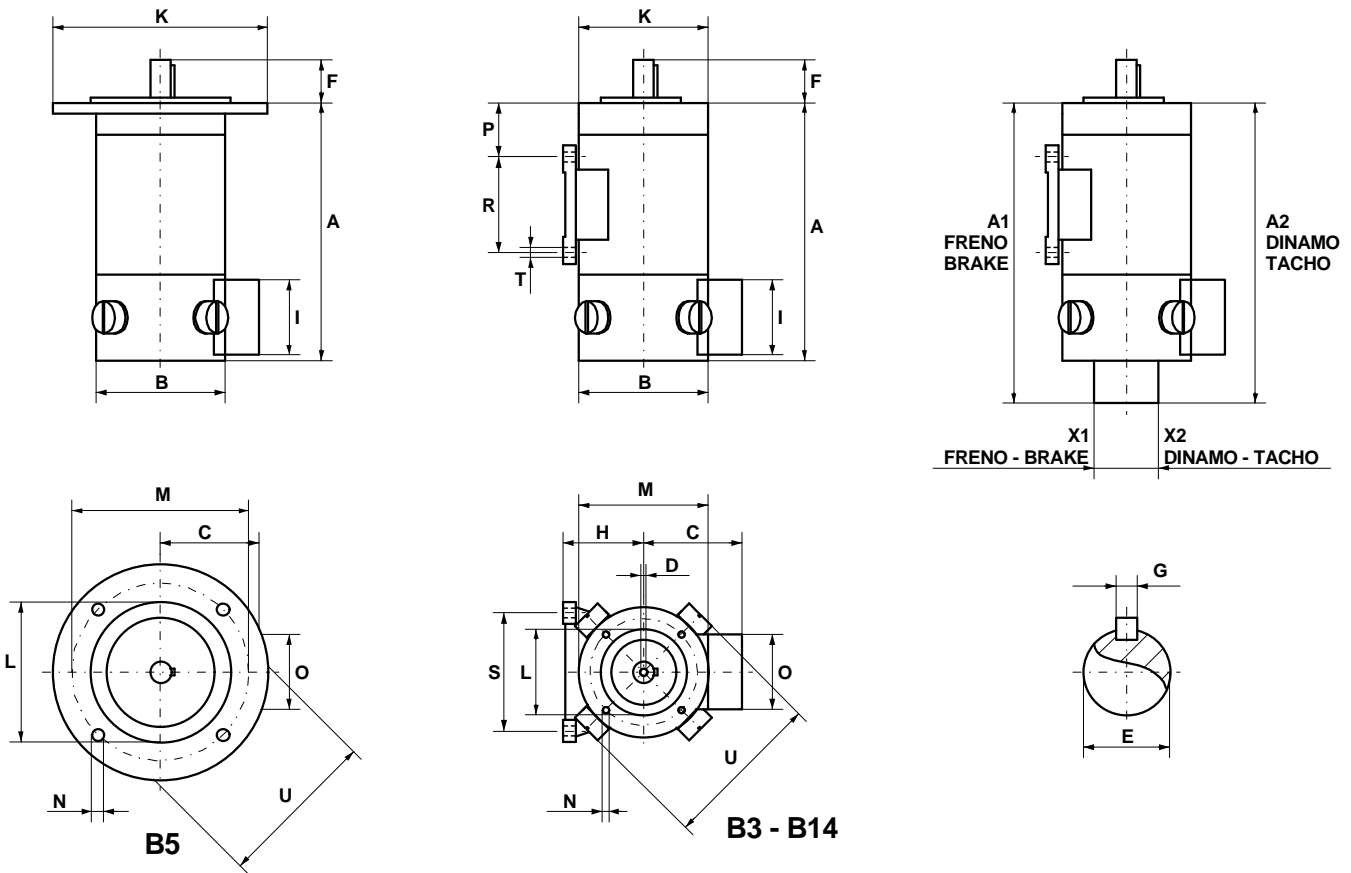

MPQ	INGOMBRO DIMENSIONS												ALBERO SHAFT			FLANGIA B5 FLANGE B5				FLANGIA B14 FLANGE B14				B3						PESO WEIGHT KG
	A	B	C	I	O	U	A1	X1	A2	X2	E	F	G	K	L	M	N	K	L	M	N	D	H	P	R	S	T			
102	204	120	92	71	71	150	261	105	284	65	14	30	5	160	110	130	9	105	70	85	M6	M5	77	38	90	112	9	8		
103	240	120	92	71	71	150	297	105	320	65	19	40	6	200	130	165	11	120	80	100	M6	M6	77	56	90	112	9	10		
104	276	120	92	71	71	150	333	105	356	65	19	40	6	200	130	165	11	120	80	100	M6	M6	77	74	90	112	9	12		
105	312	120	92	71	71	150	369	105	392	65	19	40	6	200	130	165	11	120	80	100	M6	M6	77	92	90	112	9	14		

MPQ	V	1500rpm		2000rpm		2400rpm		3000rpm		COPPIA TORQUE	CTT
		W	A	W	A	W	A	W	A		
102	12	300	32	400	44	480	51.2	600	64	Nm 1.96	Min' 60
	24	300	16	400	22	480	25.6	600	32		
103	12	450	48	600	64	720	76.4	900	96	Nm 2.94	Min' 60
	24	450	24	600	32	720	38.4	900	48		
104	12	600	66	800	86	960	106			Nm 3.92	Min' 60
	24	600	33	800	43	960	53	1200	17		
105	12	750	82	1000	110					Nm 3.92	Min' 60
	24	750	41	1000	55	1200	66	1500	82		

MPT 35 - MPT 60

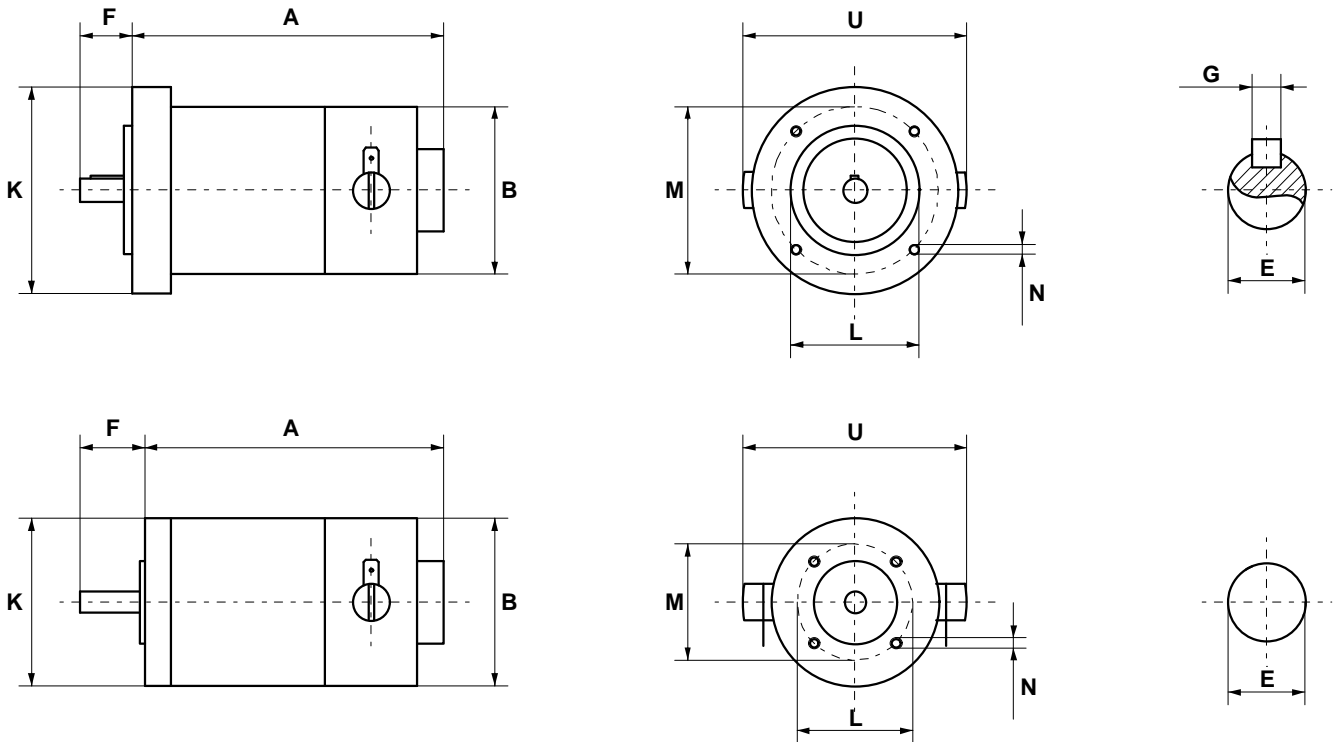

MPT	INGOMBRO DIMENSIONS			ALBERO SHAFT		FLANGIA FLANGE				OPTIONAL								PESO WEIGHT KG
										ALBERO SHAFT			FLANGIA B14 FLANGE B14					
	A	B	U	E	F	K	L	M	N	E	F	G	K	L	M	N		
35	113	65	89	8	25	65	32	46	M4	9	18	3	80	50	65	M5	1.1	
60	143	65	89	8	25	65	32	46	M4	9	18	3	80	50	65	M5	2.0	

MPT	V	1000rpm		1500rpm		2000rpm		2500rpm		3000rpm		COPPIA TORQUE	CTT
		W	A	W	A	W	A	W	A	W	A		
35	12	20	2	30	3	40	4	50	5	60	6	Nm 0.20	Min' 30
	24	20	1	30	1.5	40	2	50	2.5	60	3		
	48	20	0.5	30	0.75	40	1	50	1.25	60	1.5		
	90	20	0.27	30	0.4	40	0.53	50	0.67	60	0.8		
	170					40	0.28	50	0.35	60	0.42		
60	12	40	4.2	60	6.3	80	8.5					Nm 0.20	Min' 30
	24	40	2.1	60	3.1	80	4.2	100	5.3	120	6.4		
	48	40	1	60	1.5	80	2.1	100	2.6	120	3.2		
	90	40	0.56	60	0.84	80	1.13	100	1.4	120	1.7		
	170			60	0.44	80	0.59	100	0.74	120	0.89		

MPL 301

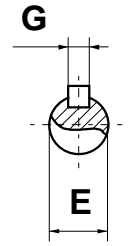
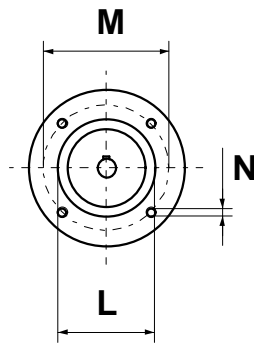
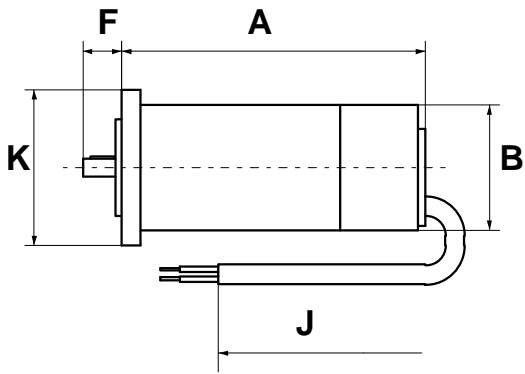

MPL 302 - 303

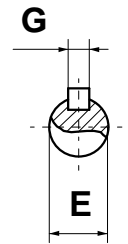
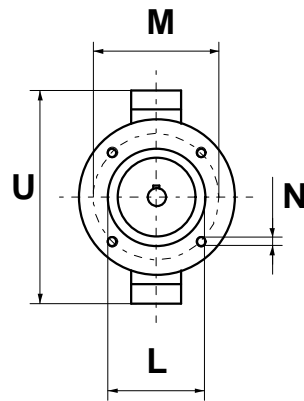
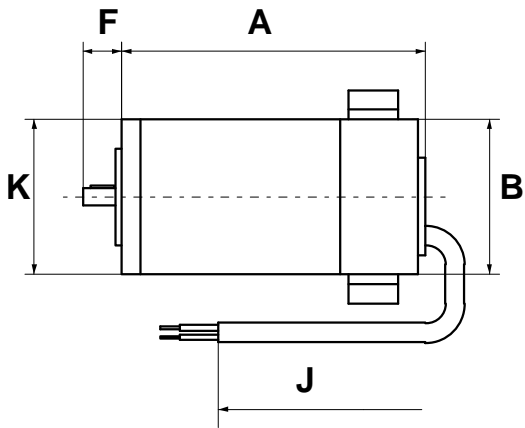

MPL 401 - 402

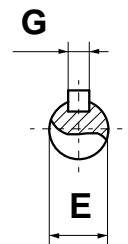
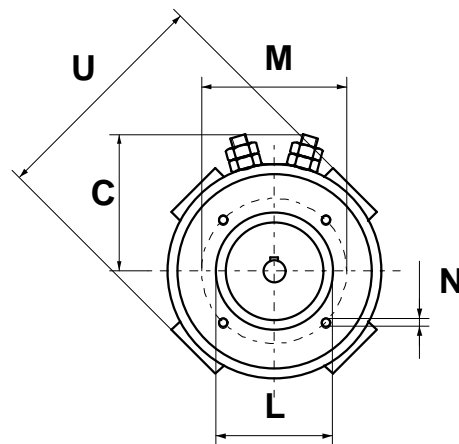
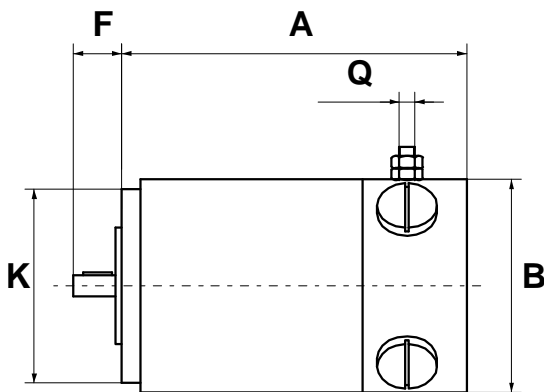

MPL

MPL	INGOMBRO DIMENSIONS						ALBERO SHAFT			FLANGIA B14 FLANGE B14				PESO WEIGHT
	A	B	J	C	Q	U	E	F	G	K	L	M	N	KG
301	135	65	1000				9	20	3	80	50	65	M5	1.7
302	157	81	1000			111	9	20	3	80	50	65	M5	2.7
303	189	81	1000			111	9	20	3	80	50	65	M5	3.4
401	198	110		77	M8	118	11	23	4	90	60	75	M5	6.5
402	238	110		77	M8	118	14	30	5	105	70	85	M6	9.5

MPT	V	1500rpm		3000rpm		COPPIA TORQUE	CTT
		W	A	W	A		
301	12	50	5.4	100	10.7	Nm 0.33	Min' 30
	24			100	5.4		
302	12	70	7.5	140	15	Nm 0.46	Min' 45
	24			140	7.5		
303	12	130	14	260	28	Nm 0.85	Min' 45
	24			260	14		
401	12	250	26.8	500	53.6	Nm 1.63	Min' 60
	24			500	26.8		
402	12	425	45.4	850	90.8	Nm 2.78	Min' 60
	24			850	45.4		

MPR

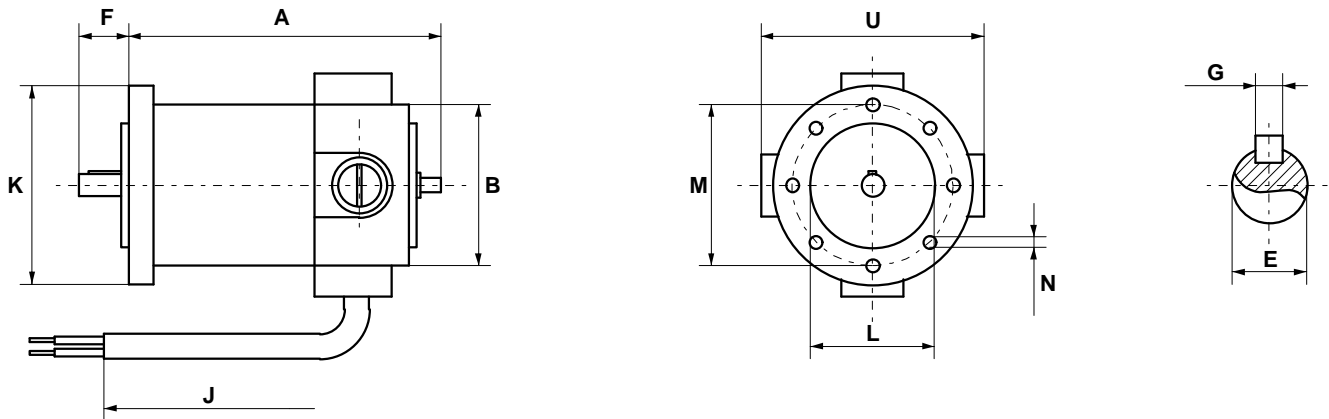

MPR	INGOMBRO DIMENSIONS				ALBERO SHAFT			FLANGIA B14 FLANGE B14				PESO WEIGHT
	A	B	J	U	E	F	G	K	L	M	N	KG
101	125	65	1000	90	9	20	3	80	50	65	M5	1.6
102	143	65	1000	90	9	20	3	80	50	65	M5	1.9

MPR	V	1500rpm		3000rpm		COPPIA TORQUE	CTT
		W	A	W	A		
101	12	80	9	160	19	0.51 Nm	30
	24			160	9		
102	12	125	14	250	30	0.80 Nm	30
	24			250	14		

FLANGE - FLANGES

MOTORE MOTOR		B14				B5			
		56	63	71	80	56	63	71	80
MPVE	56	S	R			S	R		
	56L	S	R			S	R		
	63	R	S			R	S		
	63L	R	S			R	S		
	71C		R	S			R	S	
	71		R	S			R	S	
	80			R	S				S
	80L			R	S				S
MPA	56	S	R			S	R		
	63	R	S			R	S		
	71		R	S			R	S	
	80			R	S			R	S
MPT	40	S	R			S	R		
	50	S	R			S	R		
	65	S	R			S	R		
	80	S	R			S	R		
	100	R	S			R	S		
	150	R	S			R	S		
	201		R	S			R	S	
	202		R	S			R	S	
	203			R	S			R	S
	204			R	S			R	S
MPQ	102			S	R			S	R
	103			R	S			R	S
	104			R	S			R	S
	105			R	S			R	S
MPT	35	R							
	60	R							
MPL	301	S							
	302	S							
	303	S							
	401		S						
	402			S					
MPR	101	S							
	102	S							

S = STANDARD

R = A RICHIESTA - ON REQUEST

MOTORIDUTTORI MR

I motoriduttori a vite senza fine serie MR sono realizzati con ingombri molto contenuti, poiché progettati per soddisfare le richieste di motorizzazioni che necessitano di modeste coppie motrici e dispongono di ridotti spazi di alloggiamento. Ciò nonostante hanno la medesima versatilità dei motoriduttori di dimensioni e coppie superiori.

Di norma essi vengono realizzati con albero lento cavo, a richiesta è possibile dotarli di albero lento sporgente da un lato del riduttore. Questo può essere fornito a parte, da inserire nell'albero cavo, oppure, con identiche misure della parte sporgente, integrale.

E' possibile scegliere tra due motori in corrente continua a magneti permanenti, con tensione di alimentazione da 12V a 170V, motori monofase ad induzione 230V 50Hz e motori trifase 230/400V 50Hz.

I motori in corrente continua sono privi di ventilazione e di norma dotati di faston sui portaspazzole, a richiesta è possibile dotarli di un cavo di alimentazione o di un connettore. I motori in corrente alternata sono autoventilati e dotati di morsettiera.

Tutti i motori disponibili hanno un grado di protezione agli agenti esterni IP44.

La vite senza fine è ad asse cavo e spinata sull'albero motore. Essa viene lavorata da barra d'acciaio e la filettatura è ottenuta per fresatura.

L'ingranaggio è realizzato in DELRIN, un materiale plastico con elevata resistenza alla temperatura, al taglio e all'usura. La corona grezza viene fissata sull'albero godronato con interferenza e successivamente centrato e dentato.

La lubrificazione è ottenuta con grasso a vita.

GEAR MOTORS MR

MR series worm screw gear motors are manufactured with reduced dimensions because designed to satisfy the requirements of gear motors that need small torques and have modest housing space at their disposal. Despite this, they are as versatile as larger gear motors with higher torques.

They are usually manufactured with hollow output shaft, on request they can be fitted with a shaft protruding from one side on the gear or with an output shaft to insert in the hollow shaft.

We offer a choice from two permanent magnets direct current motors, voltage from 12V to 170V, single phase motors 230V 50Hz and three phase motors 230/400V 50Hz.

The d.c.p.m. motors are no cooling, they are usually manufactured with faston on the brush-holder, on request they can have flying cable or terminal box. The a.c. motors are self-ventilated and fitted with terminal box.

All these motors are protected IP44.

The screw is hollowed and locked onto the motor shaft by a pin. It is processed from a steel rod and then milled.

The gear is manufactured from a rod of DELRIN, a plastic material with property of high resistance to temperature, cutting and wear. The raw ring gear is mounted with interference on the knurled output shaft, centred and then toothed.

Life time gease is used for lubrication.

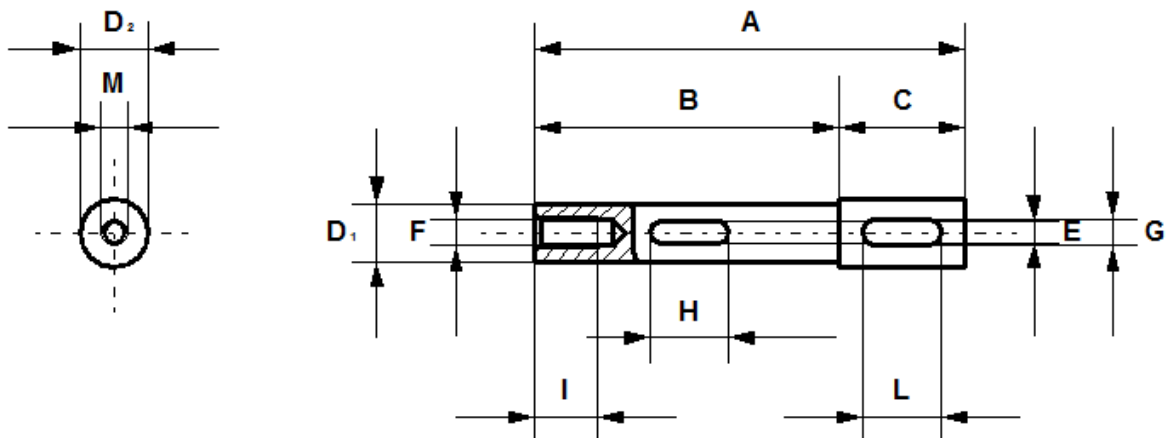

A	B	C	D ₁	D ₂	E	F	G	H	I	L	M
82	58	24	11g6	13h7	4	M6	5	15	12	15	M5

MR25DC

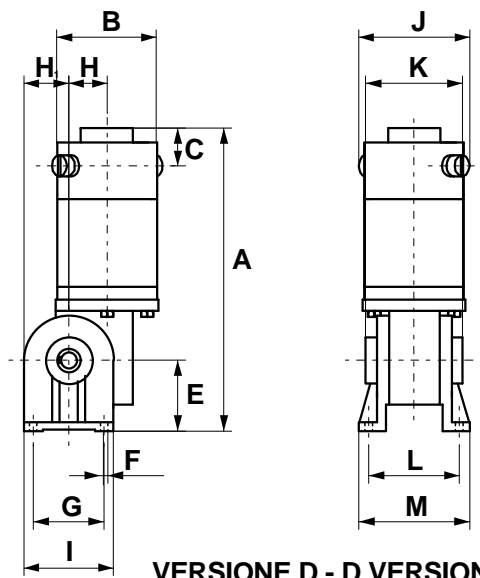
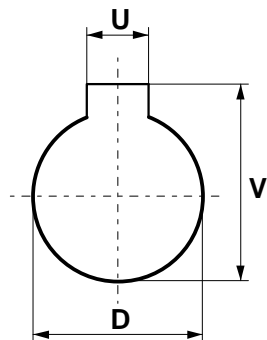

VERSIONE D - D VERSION

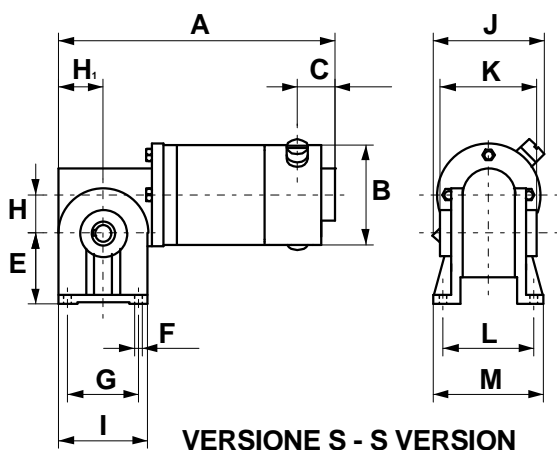

VERSIONE S - S VERSION

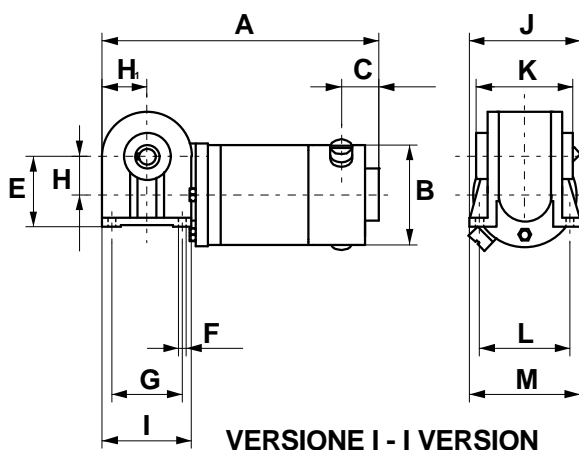

VERSIONE I - I VERSION

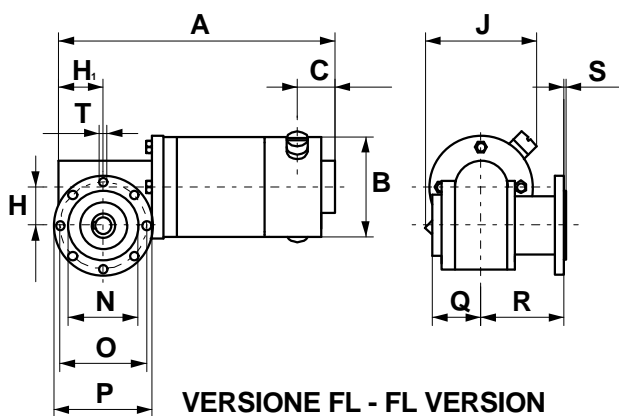

VERSIONE FL - FL VERSION

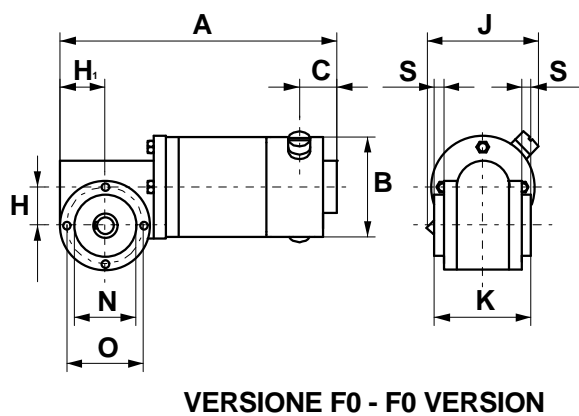

VERSIONE F0 - F0 VERSION

MR25DC	A	B	C	E	F	G	H	H ₁	I	J	K	L	M	N	O	P	Q	R	S	T	D	U	V
S	180	65	26	46	6	46	25	29	58	89	61	59	70								11H7	4	12.8
D	197	65	26	46	6	46	25	29	58	89	61	59	70								11H7	4	12.8
I	180	65	26	46	6	46	25	29	58	89	61	59	70								11H7	4	12.8
FL	180	65	26				25	29	58	89				45	56.5	65	31.5	54	1.5	5	11H7	4	12.8
F0	180	65	26				25	29	58	89	63										11H7	4	12.8

MR65DC

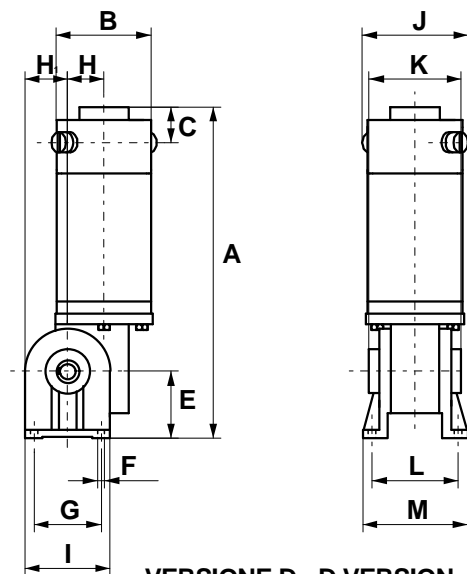
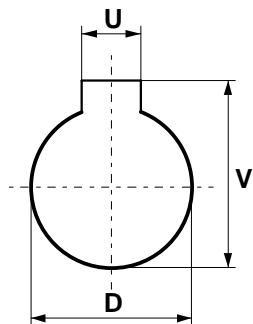

VERSIONE D - D VERSION

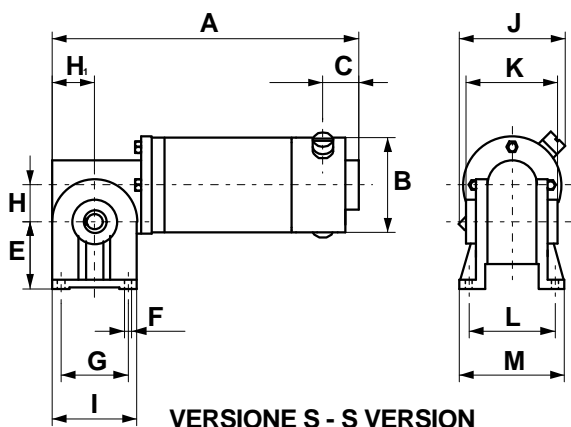

VERSIONE S - S VERSION

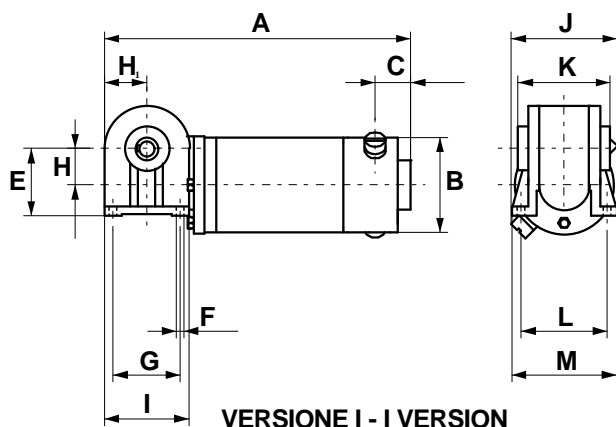

VERSIONE I - I VERSION

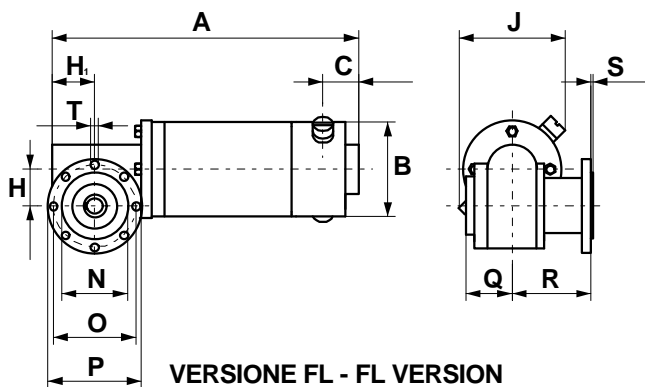

VERSIONE FL - FL VERSION

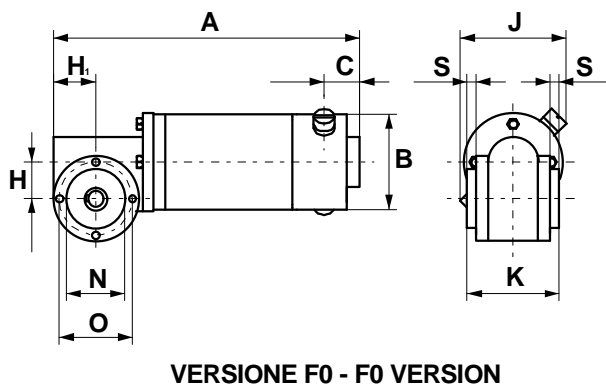

VERSIONE F0 - F0 VERSION

MR65DC	A	B	C	E	F	G	H	H ₁	I	J	K	L	M	N	O	P	Q	R	S	T	D	U	V
S	210	65	26	46	6	46	25	29	58	89	61	59	70								11H7	4	12.8
D	227	65	26	46	6	46	25	29	58	89	61	59	70								11H7	4	12.8
I	210	65	26	46	6	46	25	29	58	89	61	59	70								11H7	4	12.8
FL	210	65	26				25	29	58	89				45	56.5	65	31.5	54	1.5	5	11H7	4	12.8
F0	210	65	26				25	29	58	89	63										11H7	4	12.8

MR25DC - MR65DC

	V	i	Nm	1000rpm			1500rpm			2000rpm			2500rpm			3000rpm		
				RPM2	W	A	RPM2	W	A	RPM2	W	A	RPM2	W	A	RPM2	W	A
MR25DC	12	11,5	1.85	87	20	2	131	30	3	174	40	4	218	50	5	261	60	6
		23	3.16	44			66			88			110			132		
		28	3.66	36			54			72			90			108		
		35	4.24	29			44			58			73			87		
	24	11,5	1.85	87	20	1	131	30	1.5	174	40	2	218	50	2.5	261	60	3
		23	3.16	44			66			88			110			132		
		28	3.66	36			54			72			90			108		
		35	4.24	29			44			58			73			87		
	48	11,5	1.85	87	20	0.5	131	30	0.75	174	40	1	218	50	1.25	261	60	1.5
		23	3.16	44			66			88			110			132		
		28	3.66	36			54			72			90			108		
		35	4.24	29			44			58			73			87		
	90	11,5	1.85	87	20	0.27	131	30	0.4	174	40	0.53	218	50	0.67	261	60	0.8
		23	3.16	44			66			88			110			132		
		28	3.66	36			54			72			90			108		
		35	4.24	29			44			58			73			87		
	170	11,5	1.85							174	40	0.28	218	50	0.35	261	60	0.42
		23	3.16							88			110			132		
		28	3.66							72			90			108		
		35	4.24							58			73			87		
MR65DC	12	11,5	3.70	87	40	4.2	131	60	6.3	174	80	8.5						
		23	6.32	44			66			88								
	24	11,5	3.70	87	40	2.1	131	60	3.1	174	80	4.2	218	100	5.3	261	120	6.4
		23	6.32	44			66			88			110			132		
	48	11,5	3.70	87	40	1	131	60	1.5	174	80	2.1	218	100	2.6	261	120	3.2
		23	6.32	44			66			88			110			132		
	90	11,5	3.70	87	40	0.56	131	60	0.84	174	80	1.13	218	100	1.4	261	120	1.7
		23	6.32	44			66			88			110			132		
	170	11,5	3.70				131	60	0.44	174	80	0.59	218	100	0.74	261	120	0.89
		23	6.32							66			88			110		

MR25AC

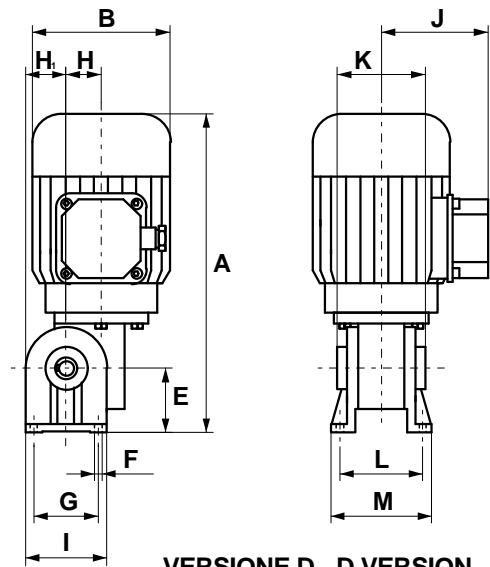
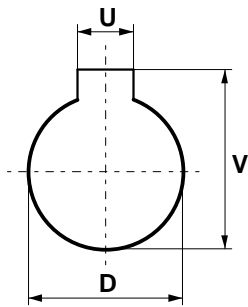

VERSIONE D - D VERSION

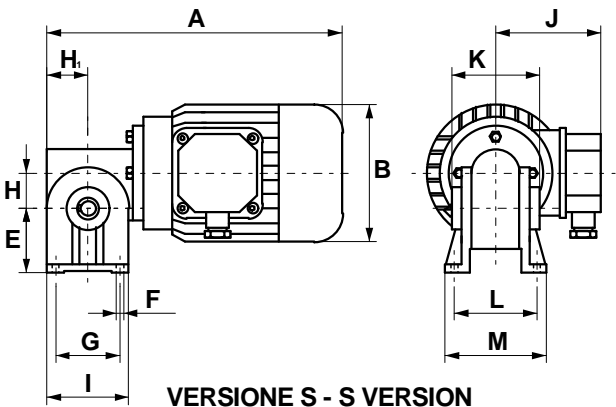

VERSIONE S - S VERSION

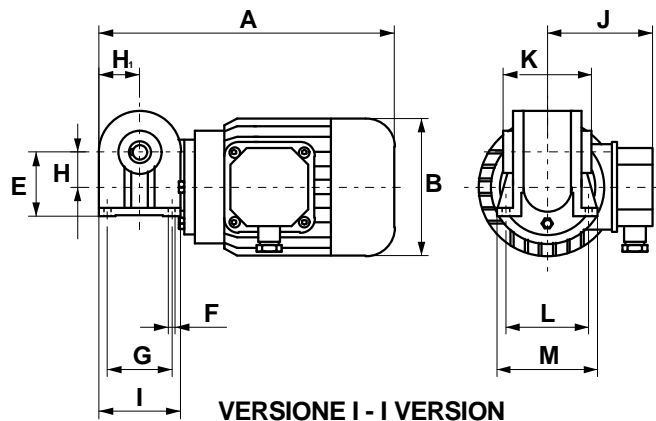

VERSIONE I - I VERSION

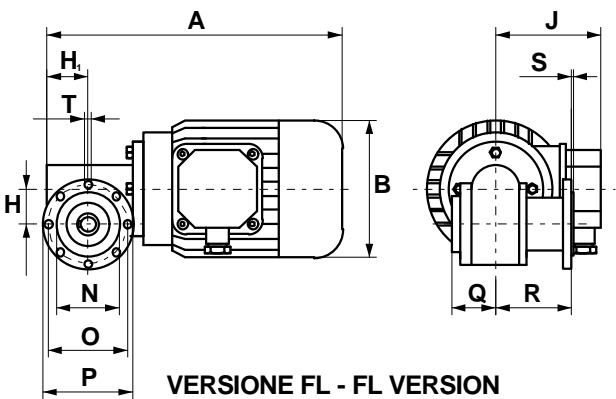

VERSIONE FL - FL VERSION

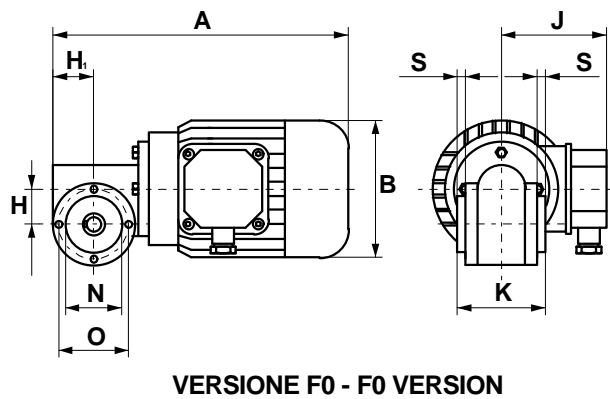

VERSIONE F0 - F0 VERSION

MR25AC	A	B	C	E	F	G	H	H ₁	I	J	K	L	M	N	O	P	Q	R	S	T	D	U	V
S	210	99	26	46	6	46	25	29	58	79	61	59	70								11H7	4	12.8
D	227	99	26	46	6	46	25	29	58	79	61	59	70								11H7	4	12.8
I	210	99	26	46	6	46	25	29	58	79	61	59	70								11H7	4	12.8
FL	210	99	26				25	29	58	79				45	56.5	65	31.5	54	1.5	5	11H7	4	12.8
F0	210	99	26				25	29	58	79	63										11H7	4	12.8

MR25AC

MR25AC		MONOFASE 4 POLI SINGLEPHASE 4 POLE		TRIFASE 4 POLI THREEPHASE 4 POLE		MONOFASE 2 POLI SINGLEPHASE 2 POLE		TRIFASE 2 POLI THREEPHASE 2 POLE	
	W	37		37		60		60	
	i	RPM2	Nm	RPM2	Nm	RPM2	Nm	RPM2	Nm
	11,5	118	2.50	118	2.50	236	1.85	236	1.85
	23	59	4.27	59	4.27	118	3.16	118	3.16
	28	48	4.97	48	4.97	96	3.68	96	3.68
	35	39	5.72	39	5.72	78	4.24	78	4.24

AZIONAMENTI

MOTOR CONTROLS

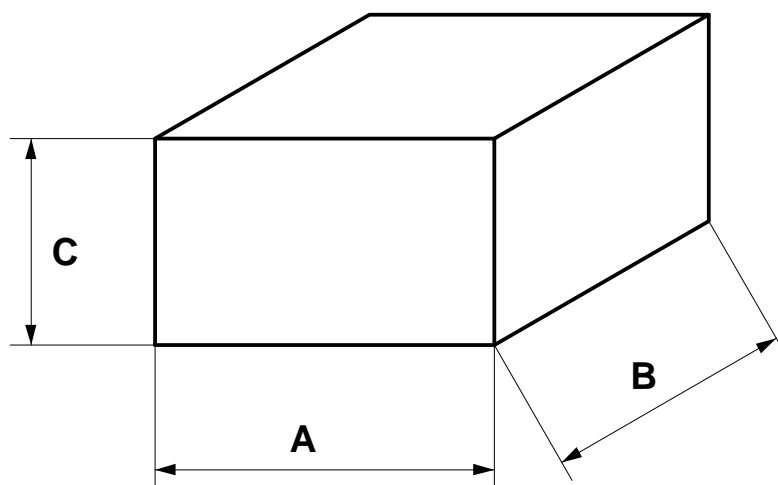

AZIONAMENTI MONODIREZIONALI PER MOTORI CORRENTE CONTINUA A MAGNETI PERMANENTI DIRECT CURRENT PERMANENT MAGNETS MOTORS CONTROLS						
TIPO TYPE	ALIMENTAZIONE INPUT	USCITA OUTPUT	CORRENTE CURRENT	A	B	C
REG3MD	24-48-110-220Vac	0/24-48-90-170Vdc	3A	82	126	41
REG5MD	24-48-110-220Vac	0/24-48-90-170Vdc	5A	96	155	43
REG10MD	24-48-110-220Vac	0/24-48-90-170Vdc	10A	125	220	60
REG15MD	24-48-110-220Vac	0/24-48-90-170Vdc	15A	126	223	104
REG20MD	24-48-110-220Vac	0/24-48-90-170Vdc	20A	126	223	104
PLN19	12-24Vac / 24Vdc	0/12-24Vdc	4A	72	87.5	40
HFR1D-60	12-24-36Vcc	0/12-24-36Vdc	21A	108	112	50
HFR1D-90	12-24-36Vcc	0/12-24-36Vdc	32A	108	135	50
HFR1D-120	12-24-36Vcc	0/12-24-36Vdc	42A	108	135	50
HFR1D-150	12-24-36Vcc	0/12-24-36Vdc	53A	108	135	50

AZIONAMENTI BIDIREZIONALI PER MOTORI CORRENTE CONTINUA A MAGNETI PERMANENTI DIRECT CURRENT PERMANENT MAGNETS MOTORS BIDIRECTIONAL CONTROLS						
TIPO TYPE	ALIMENTAZIONE INPUT	USCITA OUTPUT	CORRENTE CURRENT	A	B	C
REG 5BD	24-48-110-220Vac	0/24-48-90-170Vdc	5A	96	155	43
REG10BD	24-48-110-220Vac	0/24-48-90-170Vdc	10A	125	220	60
REG15BD	24-48-110-220Vac	0/24-48-90-170Vdc	15A	126	223	104
REG30BD	24-48-110-220Vac	0/24-48-90-170Vdc	30A	126	223	104
REG-FET 8/16	24/60Vdc - 48/120Vdc	0/48Vdc - 0/90Vdc	8A	131	60	192
REG-FET 14/28	24/60Vdc - 48/120Vdc	0/48Vdc - 0/90Vdc	14A	131	60	192
4QHR2D-45	12-24-36-48Vcc	0/12-24-36Vdc	18A	131	60	192
4QHD2D-60	12-24-36-48Vcc	0/12-24-36Vdc	21A	108	112	50
4QHF2D-90	12-24-36-48Vcc	0/12-24-36Vdc	32A	108	135	50
4QHF2D-140	12-24-36-48Vcc	0/12-24-36Vdc	48A	108	135	50

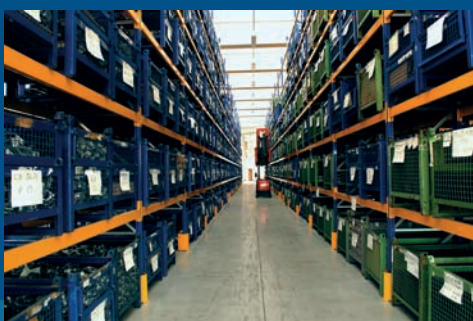

M.T. Motori Elettrici s.r.l.

Via Bologna, 175 (S.S. N. 568)

40017 San Giovanni
in Persiceto (BO)

Tel. +39 051 6875011

Fax +39 051 6871455

www.electricmotorsmt.com

info@electricmotorsmt.com

2014